

# Falcon2

## User Manual



[www.teledynedalsa.com](http://www.teledynedalsa.com)  
03-032-20107-03



© 2013 Teledyne DALSA, Inc. All information provided in this manual is believed to be accurate and reliable. No responsibility is assumed by Teledyne DALSA for its use. Teledyne DALSA reserves the right to make changes to this information without notice. Reproduction of this manual in whole or in part, by any means, is prohibited without prior permission having been obtained from Teledyne DALSA.

Document revised: 02 August 2013.

## About Teledyne Technologies and Teledyne DALSA, Inc.

Teledyne Technologies is a leading provider of sophisticated electronic subsystems, instrumentation and communication products, engineered systems, aerospace engines, and energy and power generation systems. Teledyne Technologies' operations are primarily located in the United States, the United Kingdom and Mexico. For more information, visit Teledyne Technologies' website at [www.teledyne.com](http://www.teledyne.com).

Teledyne DALSA, a Teledyne Technologies company, is an international leader in high performance digital imaging and semiconductors with approximately 1,000 employees worldwide, headquartered in Waterloo, Ontario, Canada. Established in 1980, the company designs, develops, manufactures and markets digital imaging products and solutions, in addition to providing MEMS products and services. For more information, visit Teledyne DALSA's website at [www.teledynedalsa.com](http://www.teledynedalsa.com).

## Sales and Support

For further information not included in this manual, or for information on Teledyne DALSA's extensive line of image sensing products, please contact:

### North America

700 Technology Park Drive  
Billerica, MA  
USA, 01821  
Tel: 978-670-2000  
Fax: 978-670-2010  
Email: [Sales.Americas@teledynedalsa.com](mailto:Sales.Americas@teledynedalsa.com)

### Europe

Felix-Wankel-Str. 1  
82152 Krailling  
Germany  
Tel: +49 89 89 54 57 3-80  
Fax: +49 89 89 54 57 3-46  
Email: [Sales.Europe@teledynedalsa.com](mailto:Sales.Europe@teledynedalsa.com)

### Asia Pacific

Ikebukuro East 13F  
3-4-3 Higashi Ikebukuro, Toshima-ku,  
Tokyo  
Japan  
Tel: +81 3 5960 6353  
Fax: +81 3 5960 6354  
Email: [Sales.Asia@teledynedalsa.com](mailto:Sales.Asia@teledynedalsa.com)

# Contents

System Precautions.....	6
General .....	6
Electrostatic Discharge and the CMOS Sensor.....	6
Protecting Against Dust, Oil, and Scratches.....	6
<b>1. The Falcon2 Cameras</b> .....	<b>7</b>
Camera Highlights.....	7
Camera Performance Specifications .....	9
Certifications.....	10
Shock and Vibration .....	10
Supported Industry Standards.....	11
Responsivity .....	12
Sensor Cosmetic Specifications.....	15
Sensor Block Diagram and Pixel Readout .....	16
Mechanicals.....	17
<b>2. Software and Hardware Setup</b> .....	<b>18</b>
Minimum Recommended System Requirements .....	18
Setup Steps: Overview .....	18
1. Install and Configure Frame Grabber and Software (including GUI) .....	18
2. Connect Camera Link Cables and Power .....	18
3. Establish communicating with the camera.....	18
4. Check camera LED, settings and test pattern.....	18
5. Operate the Camera .....	18
Step 1. Install and configure the frame grabber and Software.....	19
Install Frame Grabber .....	19
Install Sapera LT and CamExpert .....	19
Step 2. Connect Power, Data, and Trigger Cables.....	19
Power Connector.....	20
Camera Link Data Connector.....	21
Output Signals, Camera Link Clocking Signals.....	21
Input Signals, Camera Link .....	21
LEDs.....	21
Step 3. Establish Communication with the Camera.....	22
Power on the camera .....	22
Initialize the frame grabber .....	22
Initialize communication with the camera.....	22
Check LED Status .....	22
Software Interface.....	22
<b>4. Camera Operation</b> .....	<b>24</b>
Camera Information Category.....	24
Camera Information Feature Descriptions.....	24
Factory Settings.....	27
Saving and Restoring Camera Settings .....	28
Acquisition and Transfer Control Category .....	29
Sensor Control Category .....	30

Sensor Control Feature Descriptions .....	31
Gain and Black Level Control Details .....	36
Set Aspect Ratio .....	38
Pixel Digitization Bit Depth .....	38
Exposure Controls .....	38
Exposure Time .....	40
Internal Frame Rate .....	41
I/O Control Category.....	42
Event Control Feature Descriptions.....	43
Trigger Modes .....	49
I/O Block Diagram.....	50
CameraLink Control Lines .....	50
Opto-coupled Inputs.....	50
Opto-Coupled Outputs .....	51
Advanced Processing Control Category.....	51
Advanced Processing Control Feature Descriptions .....	53
Flat Field Correction and Defective Pixel Detection Overview .....	64
How to do an FFC Setup in the Camera.....	66
How to do a FFC Setup via Sopera CamExpert .....	68
Defective Pixel Detection and Replacement.....	73
Image Format Controls Category.....	74
Test Patterns .....	79
Multiple AOI Mode.....	81
Camera Link Transport Layer Category .....	82
CameraLink Transport Layer Feature Description.....	83
Serial Port Control Category.....	86
Feature Description.....	86
Automatic Serial Speed Detection .....	87
File Access Control Category .....	87
File Access via the CamExpert Tool .....	90
<b>Appendix A: Camera Link .....</b>	<b>92</b>
Output Signals, Camera Link Clocking Signals.....	92
Camera Link cable quality and length.....	92
Data Connector: Camera Link .....	92
<b>Appendix B: Camera, Frame Grabber Communication .....</b>	<b>97</b>
Setting Up Communication between the Camera and the Frame Grabber .....	97
<b>Appendix C: Cleaning the Sensor Window .....</b>	<b>99</b>
<b>Appendix D: Internal Flat Field Calibration Algorithms .....</b>	<b>100</b>
Offset (FPN) Calibration .....	100
Pixel Replacement Calibration .....	100
Gain (PRNU) Calibration.....	100
<b>Appendix E: Three Letter Commands .....</b>	<b>102</b>
Putting Camera In TLC Mode .....	102
Setting the Sopera's COM Port Mapping.....	103
Getting Started .....	103

The Help Command (h or ?) .....	103
Getting Parameters (gcp or get) .....	103
Commands .....	104
<b>EMC Declaration of Conformity</b> .....	<b>117</b>
<b>Revision History</b> .....	<b>118</b>
<b>Index</b> .....	<b>119</b>

# System Precautions

## General

Read these precautions and this manual carefully before using the camera.

Confirm that the camera's packaging is undamaged before opening it. If the packaging is damaged please contact the related logistics personnel.

Do not open the housing of the camera. The warranty is voided if the housing is opened.

Keep the camera housing temperature in a range of 0 °C to 50 °C during operation.

Do not operate the camera in the vicinity of strong electromagnetic fields. In addition, avoid electrostatic charging, violent vibration, and excess moisture.

To clean the device, avoid electrostatic charging by using a dry, clean absorbent cotton cloth dampened with a small quantity of pure alcohol. Do not use methylated alcohol. To clean the surface of the camera housing, use a soft, dry cloth. To remove severe stains use a soft cloth dampened with a small quantity of neutral detergent and then wipe dry. Do not use volatile solvents such as benzene and thinners, as they can damage the surface finish. Further cleaning instructions are below.

This camera does not support hot plugging. Power down and disconnect power to the camera before you add or replace system components.

## Electrostatic Discharge and the CMOS Sensor

Image sensors and the camera bodies housing are susceptible to damage from electrostatic discharge (ESD). Electrostatic charge introduced to the sensor window surface can induce charge buildup on the underside of the window that cannot be readily dissipated by the dry nitrogen gas in the sensor package cavity. The charge normally dissipates within 24 hours and the sensor returns to normal operation.

## Protecting Against Dust, Oil, and Scratches

The sensor window is part of the optical path and should be handled like other optical components, with extreme care. Dust can obscure pixels, producing dark patches on the sensor response. Dust is most visible when the illumination is collimated. The dark patches shift position as the angle of illumination changes. Dust is normally not visible when the sensor is positioned at the exit port of an integrating sphere, where the illumination is diffuse. Dust can normally be removed by blowing the window surface using an ionized air gun. Oil is usually introduced during handling. Touching the surface of the window barehanded will leave oily residues. Using rubber fingercots and rubber gloves can prevent contamination. However, the friction between rubber and the window may produce electrostatic charge that may damage the sensor. To avoid ESD damage and to avoid introducing oily residues, avoid touching the sensor. Scratches diffract incident illumination. When exposed to uniform illumination, a sensor with a scratched window will normally have brighter pixels adjacent to darker pixels. The location of these pixels will change with the angle of illumination.

For information on cleaning the sensor window, refer to the [Cleaning the Sensor Window](#) section.

---

# 1. The Falcon2 Cameras

## Camera Highlights

The Falcon2 4M, 8M, and 12M are Teledyne DALSA's new generation of area scan cameras. The Falcon2 cameras incorporate large resolutions and increased frame rates, enabling high speed image capture with superb spatial resolution.

Features such as global shutter and improved image quality make the Falcon2 cameras the camera of choice in applications where throughput, resolution, and dynamic range matter. In addition, global shuttering removes unwanted smear and time displacement artefacts related to rolling shutter CMOS devices.

Inside the Falcon2 cameras are our latest 4, 8 and 12 megapixel CMOS sensors which have reduced dark noise levels and improved dark offset, FPN (fixed pattern noise) and PRNU (Pixel Response Non-Uniformity) levels. In addition, region of interest features create opportunities for higher frame rates and new applications.

The cameras are compliant with Camera Link™ specifications, delivering 8 or 10 bits of data on 8 or 10 taps (frame rates are specified at 8 bits). Further, the M42x1 thread opening allows the use of your lens of choice.

### Key Features

- 12, 8 and 4 mega pixels
- Selectable 4:3 or 1:1 aspect ratios
- Global shutter
- Exposure control
- Faster frame rates through windowing
- Good NIR response
- Built-in FPN and PRNU correction

### Programmability

- Adjustable digital gain and offset
- 8 or 10 bit selectable output
- Adjustable integration time and frame rate
- Test patterns and camera diagnostics

### Applications

- Automated Optical Inspection (AOI)
- 3D imaging—laser profiling
- Semiconductor wafer inspection
- Solar panel inspection
- Electronics manufacturing
- Surface and bump inspection
- 3D solder paste inspection
- General machine vision

## Models

The camera is available in the following configurations.

**Table 1: Camera Models Overview**

Model Number	Description
FA-80-12M1H-XX-R	12M pixel monochrome Camera Link.
FA-81-12M1H-XX-R	12M pixel color Camera Link.
FA-80-8M100-XX-R	8M pixel monochrome Camera Link.
FA-81-8M100-XX-R	8M pixel color Camera Link.
FA-80-4M180-XX-R	4M pixel monochrome Camera Link.
FA-81-4M180-XX-R	4M pixel color Camera Link.

**Table 2: Software**

Software	Product Number / Version Number
Camera firm ware	Embedded within camera
GenICam™ support (XML camera description file)	Embedded within camera
Recommended: Spera LT, including CamExpert GUI application and GenICam for Camera Link imaging driver.	Version 7.20 or later



# Camera Performance Specifications

**Table 3: Camera Performance Specifications**

Specifications	Performance
Resolution	4 : 3 aspect ratio: 12M—4096 (H) x 3072 (V) 8M—3328 (H) x 2502 (V) 4M—2432 (H) x 1728 (V) 1 : 1 aspect ratio: 8M—2816 (H) x 2816 (V) 4M—2048 (H) x 2048 (V)
Pixel Rate	8 x 76 MHz or 10 x 76 MHz
Max. Frame Rate	12M—58 fps / 8M—90 fps / 4M—168 fps, 10 taps*
Pixel Size	6 $\mu\text{m}$ x 6 $\mu\text{m}$
Exposure Time	20 $\mu\text{s}$ minimum
Bit Depth	8 bits or 10 bits, Camera Link
Dynamic Range Mono**	58 dB, typical
Dynamic Range Color**	55 dB Green 50 dB Blue 51 dB Red
Output Format, Taps	8 or 10 tap interleaved
Operating Temp	0 °C to 50 °C, front plate temperature
<b>Connectors and Mechanicals</b>	
Data Interface	2 x Full or Extended Camera Link—SDR26
Power Connector	Hirose 12-pin circular
Power Supply	+ 12 V to + 24 V DC
Power Dissipation	9.5 W, typical
Mini-USB connector	Future use
Lens Mount	M42 x 1 (F mount optional)
Sensor Alignment	$\pm 0.2^\circ$ in X-Y directions
Size	60 mm (H) x 60 mm (W) x 80.5 mm (D)
Mass	< 300 g
<b>Compliance</b>	
Regulatory Compliance	CE and RoHS

\* Maximum frame rates are dependent on the aspect ratio used.

\*\*Typical, 12M, 10 Bits per pixel (bpp), sensor bit depth

Mono Operating Ranges	Units		Notes
Random Noise	DN rms	1.3*	Typical, FFC enabled
Responsivity	DN/ (nJ/ cm <sup>2</sup> )	See graph	Figure 1.
DC Offset	DN	0	FFC enabled
Antiblooming		>1000 x Saturation	
FPN	DN rms	1.7*	Typical, FFC enabled
PRNU	DN rms	2.6*	Typical, FFC enabled
Integral non-linearity	DN	< 2 %	

\*12M, 10 bpp, 8 taps / 10 bits Camera Link

Color Operating Ranges	Units		Notes
Random Dark Noise	DN rms	Green – 1.74* Blue –3.06* Red –2.72*	Typical, FFC enabled
Broadband Responsivity	DN/ (nJ/ cm <sup>2</sup> )	See graph	Figure 2.
DC Offset	DN	0	FFC enabled
Antiblooming		>1000 x Saturation	
FPN	DN rms	Green –1* Blue –1.8* Red –1.5*	Typical, FFC enabled
PRNU	DN rms	Green –2.2* Blue –3.1* Red –2.9*	Typical, FFC enabled
Integral non-linearity	DN	< 2 %	

\*12M, 10bpp, 8staps/ 10bits Camera Link

**Table 4: Frame Rates, Aspect Ratio, and Resolution Comparison**

Resolution	Aspect Ratio	Maximum Column	Maximum Rows	Frame Rate 8 BPP*	Frame Rate 9 BPP*	Frame Rate 10 BPP*
12M	4:3	4096	3072	58	58	58
8M	1:1	2816	2816	90	89	66
8M	4:3	3328	2502	86	86	74
4M	1:1	2048	2048	148	122	91
4M	4:3	2432	1728	168	145	108

\* Sensor bits per pixel

An online frame rate calculator is available from the Falcon2 product page on the Teledyne DALSA site, [here](#).

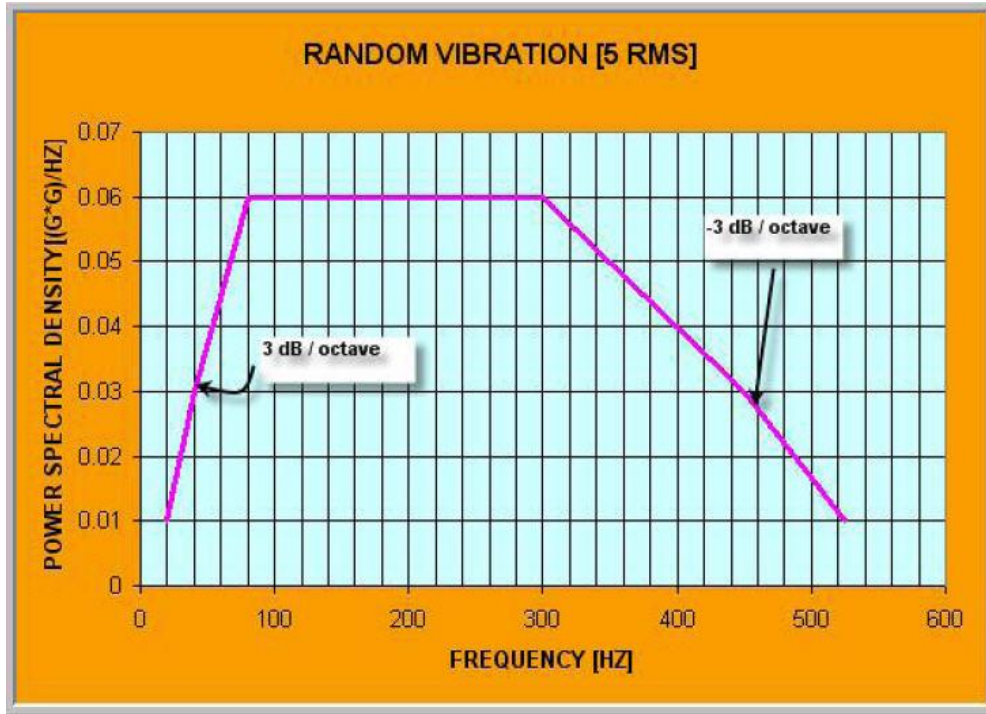
## Certifications

Compliance
EN 55011, CISPR 11, EN 55022, CISPR 22, FCC Part 15, and ICES-003 Class A Emissions Requirements. EN 55024, and EN 61326-1 Immunity to Disturbance.

## Shock and Vibration

The cameras meet or exceed the following specifications:

- Random vibration per MIL-STD-810F at 25 G<sup>2</sup>/ HZ [Power Spectral Density] or 5 RMS
- Shock testing 75 G peak acceleration per MIL-STD-810F



## Supported Industry Standards

### GenICam™

Falcon2 cameras implement a superset of the GenICam™ specification which defines device capabilities. This description takes the form of an XML device description file respecting the syntax defined by the GenApi module of the GenICam™ specification. For more information see [www.genicam.org](http://www.genicam.org).

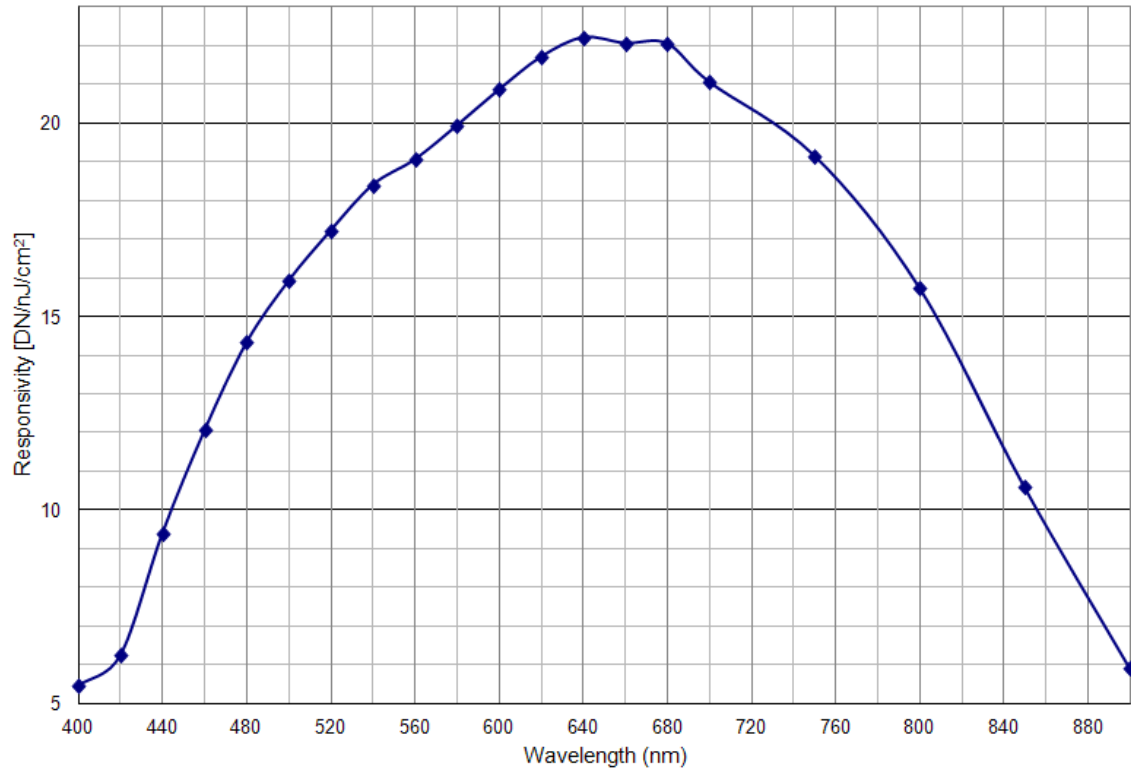
Communication between the frame grabber and camera occurs using the GenCP module (Generic Control Protocol).

Further GenICam information and documentation is available from the European Machine Vision Association's Web site ([www.emva.org](http://www.emva.org)).

# Responsivity

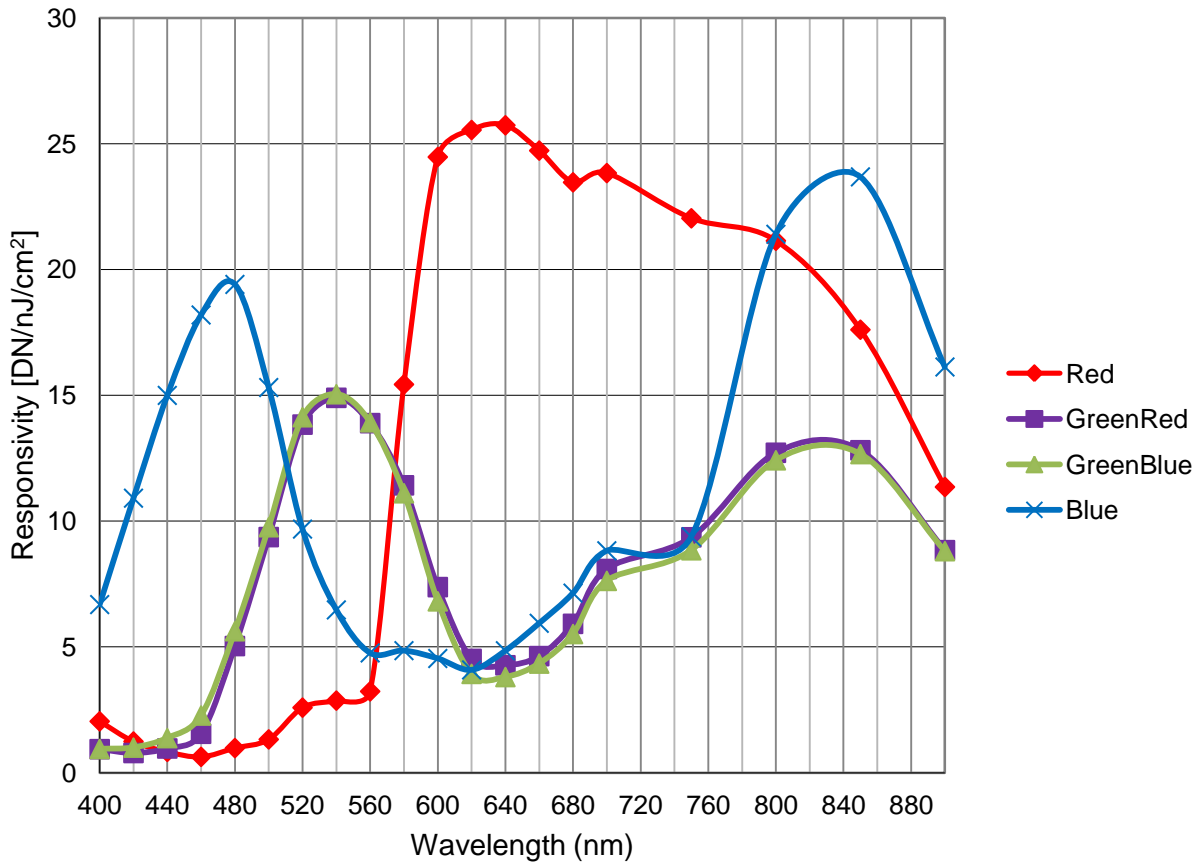
The responsivity graph describes the camera's response to different wavelengths of light (excluding lens and light source characteristics).

**Figure 1: Falcon2 Monochrome 8M Spectral Responsivity**



**Note: 8 Taps, 10 bits Camera Link, FFC on, 24 fps (except 400 nm, measured at 10 fps), ND 0.3 filtered light**

**Figure 2: Falcon2 Color 12M (4096x3072) Spectral Responsivity**



**Note: 8 taps 10 bits Camera link, 9 Bit sensor digitization, FFC on, color corrected, 4 fps (except for color red, which used different frame rate at wavelength 560nm and below: 400~480nm was done at 1.8 fps, 500 nm was done at 4 fps and 520~560), BG 38 filtered light**

**Figure 3: Quantum Efficiency**

**[INSERT QE GRAPH HERE]**

# Sensor Cosmetic Specifications

The following table lists the current cosmetic specifications for the Teledyne DALSA sensor used in the Falcon2 series.

Feature / Specification	Unit	MIN	TYP	MAX	Notes
Dark Pixel Definition - absolute output level	DN			> 500	4 frame average
Dark Pixel Count	#			50	
Light Pixel Definition - deviates from frame average	%			± 30	4 frame average image for scene & dark correction
Average Frame Output Level	% SAT	40	50	60	Illuminated with diffused light source
Tolerated Count	#			50	
Detection Threshold	-		Groups of dark and light pixels		combined dark and light pixel defects
Tolerated Count	#			7	Based on estimation algorithm
Detection Threshold			Groups of dark and light pixels		Combined dark and light pixel defects
Tolerated Count	#	-		0	
Glass Spot Defect Definition	defects/ kernel	8 / 3x3		8 / 3x3	Illuminated with aperture (collimated) light source
Detection Threshold	% of avage			± 8	4 frame average - any pixel outside ± 8% of average
Tolerated Count	#			1	1 spot of 9 pixels allowed. No limit on spots below 9 pixels
Column Defect Definition	defects/ kernel			> 8 / 1x12	
Column Defect Count	#			0	
Row Defect Definition	defects/ kernel			> 8 / 12x1	
Row Defect Count	#			0	

**Table 5: Sensor Cosmetic Specifications**

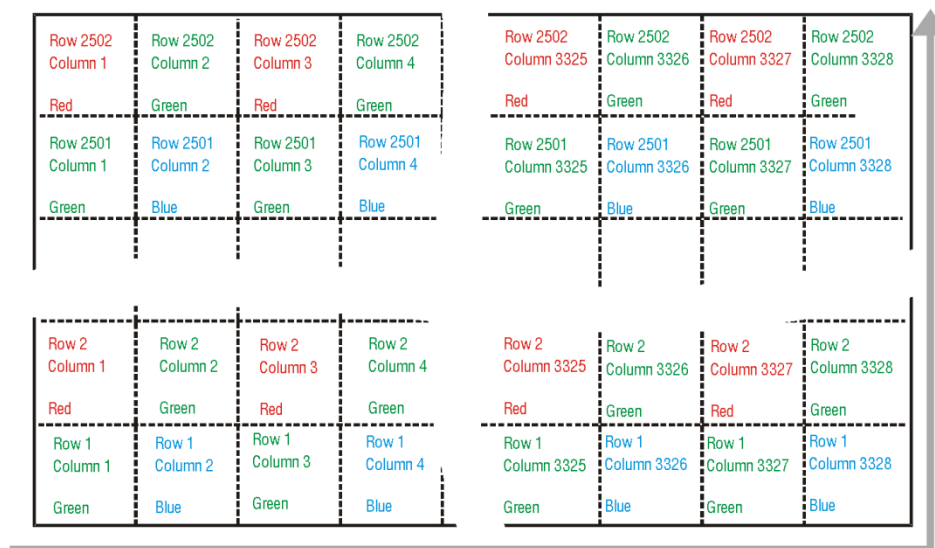
## Definition of Blemishes

- Dark pixel defect: Pixel whose signal, in dark, exceeds 500 DN.

- Light pixel defect: Pixel whose signal, at nominal light (illumination at 50 % of the linear range), deviates more than  $\pm 30\%$  from its neighbouring pixels.
- Cluster defect: A grouping of at most 2 to 5 pixel defects within a sub-area of  $3 \times 3$  pixels.
- Glass Spot defect: A grouping of 9 pixel defects within a sub-area of  $3 \times 3$  pixels.
- Column defect: A column that has more than 8 defect pixels in a  $1 \times 12$  kernel.
- Row defect: A row that has more than 8 defects in a  $12 \times 1$  kernel.
- Test conditions Temperature:  $40^\circ\text{C}$ .
- Integration Time: 12 ms.

## Sensor Block Diagram and Pixel Readout

Figure 4: 8 Tap Camera Link Configuration Sensor Block Diagram. 8M Color Camera at Aspect Ratio 4 : 3.



Pixels are read out from left to right, (R1, C1) to (R1, Cn), followed by the higher number rows.

### Notes:

- As viewed looking at the front of the camera **without a lens**. (The Teledyne DALSA logo on the side of the case will be right-side up.)
- The monochrome camera uses the same layout, but without the color filters.
- The color camera model has a Bayer filter applied to the CMOS sensor to allow for color separation. Each individual pixel is covered by either a red, green, or blue filter as shown in the figure above. The camera outputs raw color data—no color interpolation is performed. Full RGB images can be obtained by performing color interpolation on the frame grabber or host PC. For reference the green pixels horizontally adjacent to the red pixels will be referred to as Green-Red pixels while Green-Blue will be referred to the Green pixels next to the blue pixels



# Mechanicals

[ADD MECHANICAL PDF HERE]

**Figure 5: Camera Mechanical**

---

# 2. Software and Hardware Setup

## Minimum Recommended System Requirements

To achieve best system performance, the following minimum requirements are recommended:

- High bandwidth frame grabber, e.g. DALSA PX8 Full Camera link frame grabber (Part # OR-X8CO-XPF00).
- PCI x8 slot.
- Operating system: Windows XP 32-bit.

## Setup Steps: Overview

Take the following steps in order to setup and run your camera system. They are described briefly below and in more detail in the sections that follow.

### 1. Install and Configure Frame Grabber and Software (including GUI)

Install a frame grabber that supports the camera's bandwidth. Follow the manufacturer's installation instructions.

A GenICam™ compliant XML device description file is embedded within the Falcon2 firmware allowing GenCP compliant applications to know the camera's capabilities immediately after connection.

Installing SperaLT gives you access to the CamExpert GUI, a GenCP compliant application. The SperaLT software is available from the Falcon2 page of the Teledyne DALSA Web site, [here](#).

### 2. Connect Camera Link Cables and Power

- Connect the Camera Link cables from the camera to the computer.
- Connect a power cable from the camera to a +12 VDC to +24 VDC ( $\pm 5\%$ ) power supply.
- Note: once powered down, the camera must remain off for a minimum of 10 seconds before being turned on again in order to fully reboot.

### 3. Establish communicating with the camera

Start the software and establish communication with the camera.

### 4. Check camera LED, settings and test pattern

Ensure the camera is operating properly by checking the LED, the current, active settings, and by acquiring a test pattern.

---

## 5. Operate the Camera

At this point you will be ready to start operating the camera in order to acquire images, set camera functions, and save settings.

# Step 1. Install and configure the frame grabber and Software

## Install Frame Grabber

Install a compatible Camera link frame grabber according to the manufacturer's description.

We recommend the X64 Xcelera-CL PX8 frame grabber or equivalent, described in detail on the [teledynedalsa.com](http://teledynedalsa.com) site [here](#).

## Install Sopera LT and CamExpert

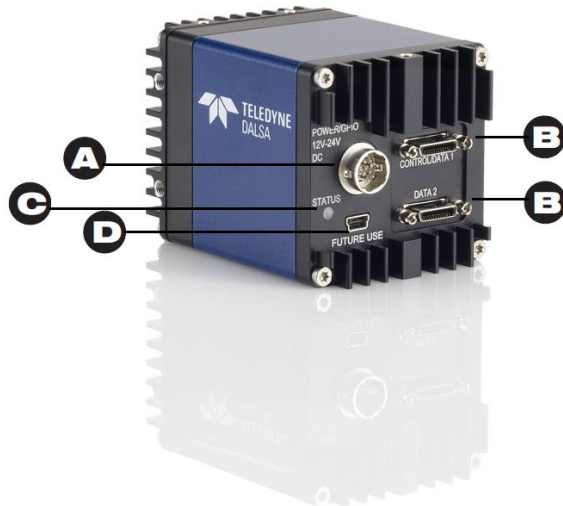
Communicate with the camera using a Camera Link-compliant interface. We recommend you use CamExpert. CamExpert is the camera interfacing tool supported by the Sopera library and comes bundled with SoperaLT. Using CamExpert is the simplest and quickest way to send commands to and receive information from the camera.

### Camera link Environment

These cameras implement the Camera link specification, which defines the device capabilities. The Camera link XML device description file is embedded within the camera firmware allowing Camera link-compliant applications to recognize the camera's capabilities immediately after connection.

# Step 2. Connect Power, Data, and Trigger Cables

Note: the use of cables types and lengths other than those specified may result in increased emission or decreased immunity and performance of the camera.



#### Power

- A** + 12 V to + 24 V DC Hirose 12-pin

#### Control & Data

- B** Mini-Camera Link SDR26 connectors

#### Status

- C** Diagnostic LED

#### Future Use

- D** Mini-USB connector

**Figure 6: Input and Output, trigger, and Power Connectors**



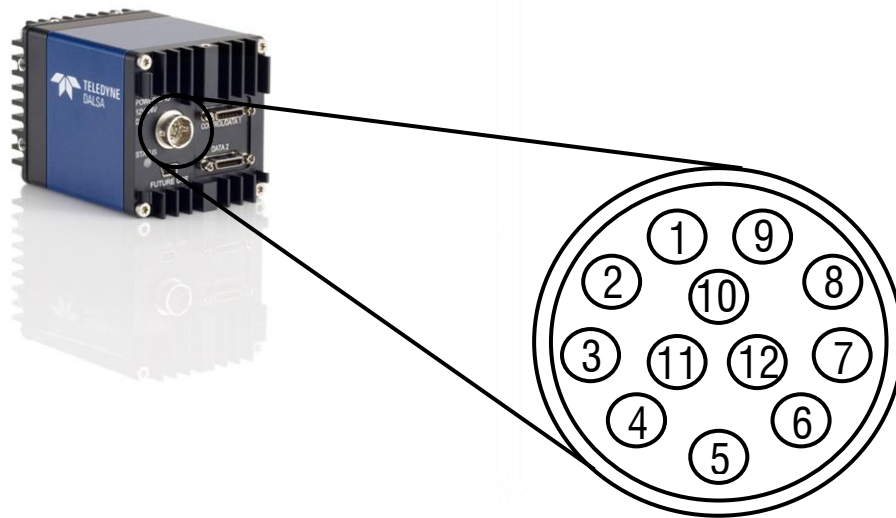
### WARNING! Grounding Instructions

Static electricity can damage electronic components. It's critical that you discharge any static electrical charge by touching a grounded surface, such as the metal computer chassis, before performing handling the camera hardware.

## Power Connector



**WARNING:** It is extremely important that you apply the appropriate voltages to your camera. Incorrect voltages may damage the camera. Input voltage requirement: +12 VDC to +24 VDC ( $\pm 5\%$ ), 2 Amps. Before connecting power to the camera, test all power supplies.



**Figure 7: 12-pin Hirose Circular Male Power Plug—Power Connector**

**Table 6. Power Plug Pinout**

Pin	Description	Pin	Description
1	GND	7	OUT1_C1/ Strobe_C1
2	+12 V to +24 V DC	8	OUT1_C0/ Strobe_C0
3	OUT0_C1	9	GND
4	OUT0_C2	10	+12 V to +24 V DC
5	IN1-	11	IN2+/ Trigger
6	IN1+	12	IN2-/ Trigger

### **WARNING:** When setting up the camera's power supplies follow these guidelines:



- Apply the appropriate voltages.
- Protect the camera with a 2 amp slow-blow fuse between the power supply and the camera.
- Do not use the shield on a multi-conductor cable for ground.
- Keep leads as short as possible in order to reduce voltage drop.
- Use high-quality linear supplies in order to minimize noise.

**Note:** If your power supply does not meet these requirements, then the camera performance specifications are not guaranteed.

## Camera Link Data Connector

The cameras use two mini-Camera Link SDR-26 cables transmitting the Camera Link Full or Extended configuration. For a description of the connectors and the Full and Extended configurations refer here, [Data Connector: Camera Link](#).

## Output Signals, Camera Link Clocking Signals

These signals indicate when data is valid, allowing you to clock the data from the camera to your acquisition system. These signals are part of the Camera Link configuration and you should refer to the Camera Link Implementation Road Map, available at our [Knowledge Center](#), for the standard location of these signals.

## Input Signals, Camera Link

The camera accepts control inputs through the mini-Camera Link SDR-26F connector.

The camera ships (factory setting) in internal sync, and internally triggered integration.

### Frame Start Trigger (EXSYNC)

The EXSYNC signal tells the camera when to integrate and readout the image. It can be either an internally generated signal by the camera, or it can be supplied externally via CC, GPIO, and software command.

## LEDs

The camera is equipped with an LED on the back to display the operational status of the camera. The table below summarizes the operating states of the camera and the corresponding LED states. When more than one condition is active, the LED indicates the condition with the highest priority.

Color of Status LED	Meaning
Off	No power or hardware malfunction
Red solid	Warning (e.g. temperature)
Red solid	Fatal error state
Blue solid	Upgrading internal firmware
Blue slow blinking	Camera waiting for warm up to complete
Blue solid	At initial power up and when acquisition is disabled. This happens when changing a camera feature that effects the image output (e.g. aoi, bit depth, etc.)
Green solid	Free-running acquisition

# Step 3. Establish Communication with the Camera

## Power on the camera

Turn on the camera's power supply. You may have to wait up to 60 seconds for the camera to warm up and prepare itself for operation. The camera must boot fully before it will be recognized by the GUI—the LED turns green once the camera is ready.

## Initialize the frame grabber

1. Start Sapera CamExpert (or an equivalent GenCP-compliant interface) by double clicking the desktop icon created during the software installation.
2. CamExpert will search for Sapera devices installed on your system. In the Devices list area on the left side of the GUI, the connected frame grabber will be shown.
3. Select the frame grabber device by clicking on its name.

Note: The first time you set up the camera you will need to establish a communication link between the camera and frame grabber. Instructions are available in the appendix, [here](#).

## Initialize communication with the camera

1. Start a new Sapera CamExpert application (or equivalent Camera Link compliant interface) by double clicking the desktop icon created during the software installation.
2. CamExpert will search for Sapera devices installed on your system. In the Devices list area on the left side of the GUI, the connected Falcon2 camera will be shown.
3. Select the Falcon2 camera device by clicking on the camera's user-defined name. By default the camera is identified by its serial number.

## Check LED Status

At this point, if the camera is operating correctly the diagnostic LED will flash blue for approximately 10 seconds and then turn solid green.

## Software Interface

All the camera features can be controlled through the GUI. For example, under the Sensor Control menu in the camera window you can control the frame rate and exposure times.

Note: the camera uses two instances of CamExpert. One window controls the camera and one displays the output received from the frame grabber.

Also Note: If CamExpert is running during a camera reset operation, then you will have to reload the GUI window used to control the camera once the camera is powered up again. Do this by either (1) closing and reopening the CamExpert window, or (2) by going to "Image Viewer" in the "Device" tab and selecting the camera again.

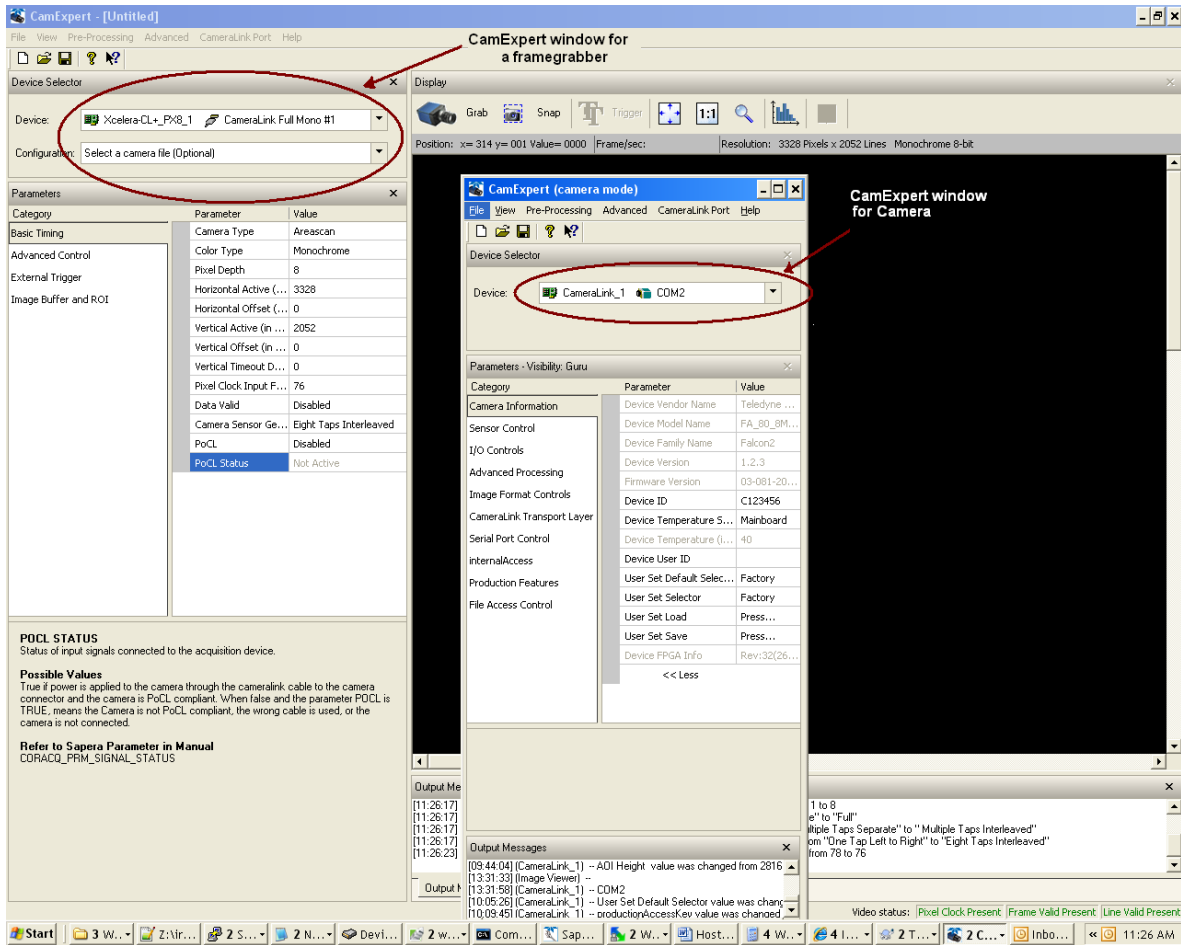


Figure 8: Two CamExpert windows shown: one connected to the frame grabber and one connected to the camera

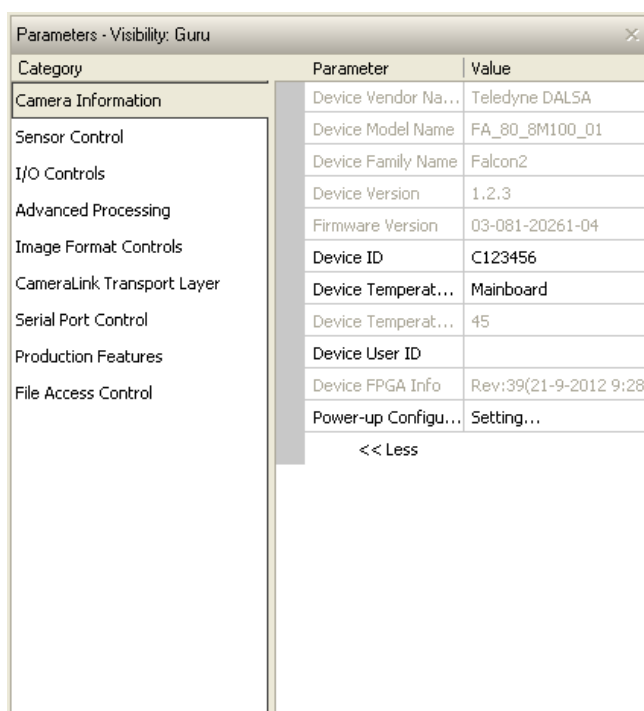
At this point you are ready to start operating the camera in order to acquire images, set camera functions, and save settings.

# 4. Camera Operation

## Camera Information Category

The camera information group provides general information about the camera. Parameters such as camera model and firmware version uniquely identify the connected device. As well, temperature can be monitored and user sets can be save and loaded to and from the camera's non-volatile memory using the features grouped here.

In this category, the number of features shown are identical whether the view is Beginner, Expert, or Guru. Features listed in the description table but tagged as *Invisible* are usually for Teledyne DALSA or third party software usage—and not typically required by end-user applications.



Category	Parameter	Value
Camera Information	Device Vendor Na...	Teledyne DALSA
Sensor Control	Device Model Name	FA_80_8M100_01
I/O Controls	Device Family Name	Falcon2
Advanced Processing	Device Version	1.2.3
Image Format Controls	Firmware Version	03-081-20261-04
CameraLink Transport Layer	Device ID	C123456
Serial Port Control	Device Temperat...	Mainboard
Production Features	Device Temperat...	45
File Access Control	Device User ID	
	Device FPGA Info	Rev:39(21-9-2012 9:28)
	Power-up Configu...	Setting...
	<< Less	

Figure 9: Camera Information Category in CamExpert

## Camera Information Feature Descriptions

The following table describes these parameters along with their view attribute and in which firmware version the feature was introduced.

Additionally, the Name category indicates which parameter is a member of the DALSA Features Naming Convention (using the tag **DFNC**), versus the GenICam Standard Features Naming Convention (SFNC), and which is a custom camera feature. As Falcon2 capabilities evolve the firmware release tag will increase; thereby identifying the supported function package.



<b>Name</b>	<b>DeviceVendorName</b>
Display Name	[Device] <b>Vendor Name</b>
Name Space	SFNC
Firmware Release	00
Visibility	Beginner
Access	Read-only
Type	String
Values	Teledyne DALSA
<b>Name</b>	<b>DeviceModelName</b>
Display Name	[Device] <b>Model Name</b>
Name Space	Standard
Firmware Release	00
Visibility	Beginner
Access	Read-only
Type	String
Values	e.g. —FA_80_8M100_01
<b>Name</b>	<b>DeviceFamilyName</b>
Display Name	[Device] <b>Family Name</b>
Name Space	Standard
Firmware Release	00
Visibility	Beginner
Access	Read-only
Type	String
Values	Falcon2
<b>Name</b>	<b>DeviceVersion</b>
Display Name	<b>Device Version</b>
Name Space	Standard
Firmware Release	00
Visibility	Beginner
Access	Read-only
Type	String
Values	e.g. —255.90.259
Notes	This is an automatically generated number that specifically identifies the software build.
<b>Name</b>	<b>DeviceFirmwareVersion</b>
Display Name	<b>Firmware Version</b>
Name Space	Standard
Firmware Release	00
Visibility	Beginner
Access	Read-only
Type	String
Values	e.g. —03-081-20261-05
Notes	The release number of the camera's firmware.
<b>Name</b>	<b>DeviceTemperatureSelector</b>
Display Name	[Device] <b>Temperature Selector</b>
Name Space	Standard
Firmware Release	00
Visibility	Beginner
Access	Read-Write
Type	Enumeration
Values	<i>Sensor</i> - temperature sensor on sensor board <i>Mainboard</i> - temperature sensor on main board
Notes	Changing this value will force the camera to read and update the <i>DeviceTemperature</i> Feature.

<b>Name</b>	<b>DeviceTemperature</b>
Display Name	<b>Temperature ( C )</b>
Name Space	Standard
Firmware Release	00
Visibility	Expert
Access	Read-only
Type	Float
Units	degrees Celsius
Values	0 - 100 C
Notes	Depending on the host application (e.g. GUI). This value is a polled value and may automatically be updated every second. Otherwise the value will only be updated upon connection or when the temperature selector is changed.
<b>Name</b>	<b>DeviceUserID</b>
Display Name	<b>Device User ID</b>
Name Space	Standard
Firmware Release	00
Visibility	Beginner
Access	Read-Write
Type	String
Values	e.g. —My Camera
Notes	This feature is automatically saved to the camera's non volatile memory when it is written.
<b>Name</b>	<b>UserSetDefaultSelector</b>
Display Name	[User Set Default Selector] <b>Power-up Configuration</b>
Name Space	Standard
Firmware Release	00
Visibility	Beginner
Access	Read-Write
Type	Enumeration
Values	<i>None</i> - no default set is loaded. The camera uses model default values and no factory calibrated values <i>Factory</i> - load factory calibrated defaults <i>UserSetx</i> —load previously saved user set <b>x</b> (where <b>x</b> is number between 1 and 4)
Notes	Selects the camera configuration set to load and make active on camera power-up or reset. The camera configuration sets are stored in camera non-volatile memory. The feature value automatically saved to the camera's non-volatile memory when it is written.
<b>Name</b>	<b>UserSetSelector</b>
Display Name	<b>User Set Selector</b>
Name Space	Standard
Firmware Release	00
Visibility	Beginner
Access	Read-Write
Type	Enumeration
Values	<i>Factory</i> - factory calibrated defaults <i>UserSetx</i> —previously saved user set <b>x</b> (where <b>x</b> is number between 1 and 4)
Notes	Selects the camera configuration set to load feature settings from or save current feature settings to. The Factory set contains default camera feature settings. Disabled when <i>flatfieldCorrectionMode = Calibration</i> .
<b>Name</b>	<b>UserSetLoad</b>
Display Name	<b>User Set Load</b>
Name Space	Standard
Firmware Release	00
Visibility	Beginner
Access	Read-Write
Type	Command
Notes	Loads the camera configuration set specified by the User Set Selector feature, from the camera and makes it active. Disabled when <i>flatfieldCorrectionMode = Calibration</i> .

Name	UserSetSave
Display Name	User Set Save
Name Space	Standard
Firmware Release	00
Visibility	Beginner
Access	Read-Write
Type	Command
Notes	Saves the camera configuration set specified by the User Set Selector feature, to the camera. Disabled when <i>flatfieldCorrectionMode = Calibration</i> or <i>UserSetSelector = Factory</i> .

## Invisible Features

Name	deviceDFNCVersionMajor
Display Name	DFNC Major revision
Name Space	DFNC
Firmware Release	00
Visibility	Invisible
Access	Read-only
Type	Integer
Values	1
Notes	Major revision of Dalsa Feature Naming Convention which was used to create the device's XML.
Name	deviceDFNCVersionMajor
Display Name	DFNC Major revision
Name Space	DFNC
Firmware Release	00
Visibility	Invisible
Access	Read-only
Type	Integer
Values	0
Notes	Minor revision of Dalsa Feature Naming Convention which was used to create the device's XML.

## Factory Settings

The camera ships and powers up for the first time with the following factory settings:

- Flat field coefficients enabled (calibrated in internal exposure mode, non-concurrent readout and integration).
- Internal exposure mode (internal frame rate and exposure time).
- Maximum frame rate and exposure time.
- Extended Camera Link mode 10 taps, 8 bits, 76 MHz pixel rate.
- 4:3 aspect ratio.

## Saving and Restoring Camera Settings

When the user changes a camera parameter, the settings are stored in the camera's *volatile* memory and will be lost if the camera resets or is powered down. To save these settings for reuse, they must be saved to the camera's non-volatile memory using the **User Set Save** parameter. Previously saved user setting (User Set 1 to 4) or the factory settings can be restored using the User Set Selector and User Set Load parameters.

Either the Factory or one of the User settings can be specified as the Default Set by selecting it in the User Set Default Selector. The chosen set is automatically loaded when the camera is reset or powered up. It should also be noted that the value of Default Selector will automatically get save in non-volatile memory whenever it is changed

The relationship between these three settings is illustrated in Figure 10.

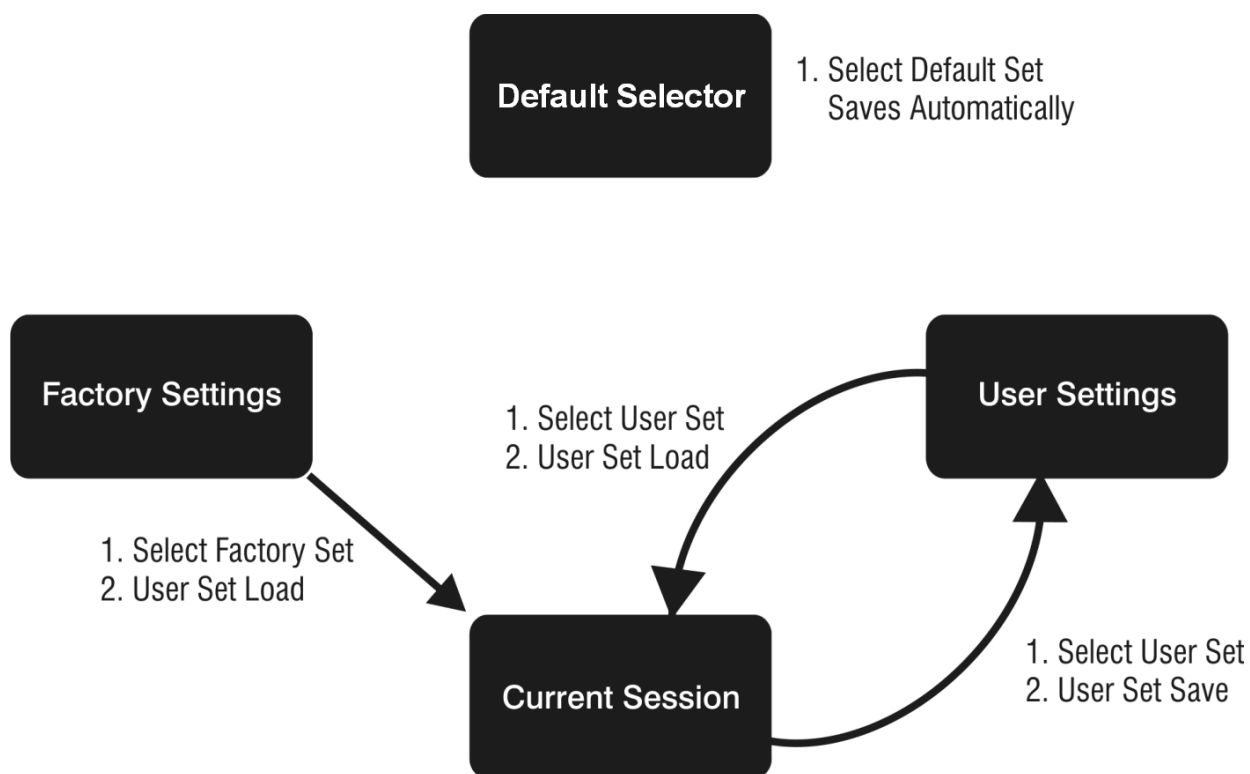


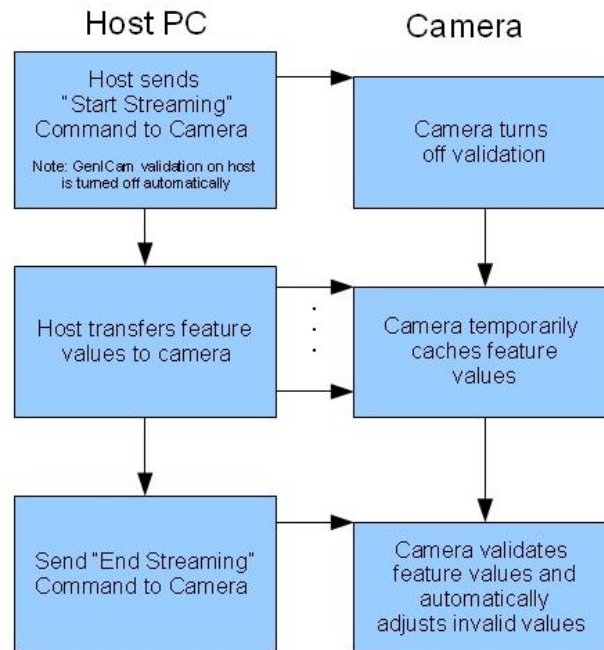
Figure 10: Relationship between the Camera Settings

NOTE: If a test pattern is active when you save the **User set**, the camera will turn off all digital processing upon restart. For example:

1. Set the test image selector to FPN Diagonal Pattern.
2. Do FPN Calibration and save the coefficient set.
3. Change the FFC mode to *ActiveAll*.
4. Set the default selector to *UserSet1*.
5. Save **User Set 1**.
6. Power cycle the camera.
7. Reconnect to the camera through CamExpert.
8. The FFC mode will be *Off* when it should be *ActiveAll*.

# Acquisition and Transfer Control Category

This category contains invisible registers that support feature streaming. Feature streaming is the process where feature values are read from or written to the camera in a batch. Validation of the data is postponed until the streaming is ended. See figure below.



**Figure 11 Streaming Feature Data to the Camera**

Feature Validation is turned off in this mode so that the order in which the feature values are set is irrelevant. For example, if validation was on during this process *AcquisitionFrameRate* would have to be set before *ExposureTime* because the maximum *ExposureTime* can be limited by the camera's frame rate.

CamExpert uses feature streaming when saving or loading the camera's ccf file. This file can be used to clone cameras so that they have the same settings. Most GUIs and SDKs will hide this functionality.

<b>Name</b>	<b>DeviceRegistersStreamingStart</b>
Display Name	<b>Device Registers Streaming Start</b>
Name Space	SFNC
Firmware Release	05
Visibility	Invisible
Access	Read-Write
Type	Command
Notes	Announces the start of registers streaming without immediate checking for consistency.
<b>Name</b>	<b>DeviceRegistersStreamingEnd</b>
Display Name	<b>Device Registers Streaming End</b>
Name Space	SFNC
Firmware Release	05
Visibility	Invisible
Access	Read-Write
Type	Command
Notes	Announces end of registers streaming and performs validation for registers consistency

	before activating them.
<b>Name</b>	<b>DeviceRegistersPersistenceStart</b>
Display Name	<b>Device Registers Persistence Start</b>
Name Space	SFNC
Firmware Release	05
Visibility	Invisible
Access	Read-Write
Type	Command
Notes	Available and automatic with GenAPI 2.4. Called first before a camera configuration feature save with third party SDK if it is not GenAPI 2.4 compliant.
<b>Name</b>	<b>DeviceRegistersPersistenceEnd</b>
Display Name	<b>Device Registers Persistence End</b>
Name Space	SFNC
Firmware Release	05
Visibility	Invisible
Access	Read-Write
Type	Command
Notes	Available and automatic with GenAPI 2.4. Called after a camera configuration feature save with third party SDK if it is not GenAPI 2.4 compliant.
<b>Name</b>	<b>DeviceRegistersCheck</b>
Display Name	<b>Registers Check</b>
Name Space	SFNC
Firmware Release	05
Visibility	Invisible
Access	Read-Write
Type	Command
Notes	Performs an explicit register set validation for consistency.
<b>Name</b>	<b>DeviceRegistersValid</b>
Display Name	<b>Registers Valid</b>
Name Space	SFNC
Firmware Release	05
Visibility	Invisible
Access	Read-Write
Type	Boolean
Notes	States if the current register set is valid and consistent.

## Sensor Control Category

The Falcon2 sensor controls, as shown by CamExpert, groups sensor specific parameters. Parameters in gray are read only, either always or due to another parameter being disabled. Parameters in black are user set in CamExpert or programmable via an imaging application.

Features listed in the description table but tagged as *Invisible* are usually for Teledyne DALSA or third party software usage—not typically needed by end user applications.

Parameter	Value
Device Scan Type	Areascan
Sensor Color Type	Monochrome
Sensor Width	3328
Sensor Height	2502
Frame Rate	27.375
Exposure - Mode	Timed
Exposure Time	36475
Gain Selector	All Digital
Gain	1
Black Level Selector	Digital Before FFC
Black Level	0
Input Pixel Size	10 BPP
Sensor Aspect Ratio	4:3 Aspect Ratio

## Sensor Control Feature Descriptions

The following table describes these parameters along with their view attribute and minimum camera firmware version required. Additionally the firmware column will indicate which parameter is a member of the DALSA Features Naming Convention (DFNC) versus the GenICam Standard Features Naming Convention (SFNC) or a custom camera feature.

<b>Name</b>	<b>DeviceScanType</b>
Display Name	<b>Device Scan Type</b>
Name Space	Standard
Firmware Release	00
Visibility	Beginner
Access	Read-only
Type	Enumeration
Values	"Areascan"
<b>Name</b>	<b>sensorColorType</b>
Display Name	<b>Sensor Color Type</b>
Name Space	DFNC
Firmware Release	04
Visibility	Beginner
Access	Read-only
Type	Enumeration
Values	"Monochrome" for monochrome camera "CFA Bayer Sensor" for color camera (CFA = Color filter array)

<b>Name</b>	<b>SensorWidth</b>
Display Name	<b>Sensor Width</b>
Name Space	Standard
Firmware Release	00
Visibility	Beginner
Access	Read-only
Type	Integer
Values	See Table 8 for maximum width for given model and aspect ratios
Notes	The maximum width (in pixels) of the AOI for the given aspect ratio ( <i>sensorResolutionAspectRatio</i> )
<b>Name</b>	<b>SensorHeight</b>
Display Name	<b>Sensor Height</b>
Name Space	Standard
Firmware Release	00
Visibility	Beginner
Access	Read-only
Type	Integer
Values	See Table 8 for maximum Height for given model and aspect ratios
Notes	The maximum height (in pixels) of the AOI for the given aspect ratio ( <i>sensorResolutionAspectRatio</i> )
<b>Name</b>	<b>AcquisitionFrameRate</b>
Display Name	<b>Frame Rate</b>
Name Space	Standard
Firmware Release	00
Visibility	Beginner
Access	Read-Write (Read-only when TriggerMode equals "On")
Type	Float
Units	Hertz
Values	1 to x Hz (where x is a calculated maximum. See Notes.)
Notes	Specifies the camera internal frame rate, in Hz. Note that any user entered value is automatically adjusted to a valid camera value. The maximum value of the frame rate is the result of a complicated formula and is dependant on the following features: <i>Width, Height, deviceTapCount, PixelFormat, pixelSizeInput</i>
<b>Name</b>	<b>AcquisitionFrameRateRaw</b>
Name Space	Standard
Firmware Release	00
Visibility	Invisible
Access	Read-Write
Type	Integer
Units	Ns
Values	100 to 10,000,000 in 100 ns increments.
Notes	This is actually the internal frame period.
<b>Name</b>	<b>ExposureMode</b>
Display Name	<b>Exposure Mode</b>
Name Space	Standard
Firmware Release	00
Visibility	Beginner
Access	Read-Write
Type	Enumeration
Values	Timed - The exposure duration time is set using the ExposureTime feature TriggerWidth - Uses the width of the current Frame trigger signal pulse to control the exposure duration (see <i>TriggerSource</i> feature). Valid only when <i>TriggerMode</i> is equal to <i>On</i> and <i>TriggerSource</i> is not Software Controlled.
Notes	Specifies the method to control the exposure time of the camera.



<b>Name</b>	<b>ExposureTime</b>								
Display Name	<b>Exposure Time</b>								
Name Space	Standard								
Firmware Release	00								
Visibility	Beginner								
Access	Read-Write (Read-only when <i>ExposureMode</i> equals <i>Timed</i> )								
Type	Integer								
Units	$\mu$ s								
Values	<p><b>Internal Trigger:</b> 20<math>\mu</math>s to (1/ <i>AquisitionFrameRate</i>-overhead)</p> <table border="1"> <thead> <tr> <th>Bit Depth</th> <th>overhead</th> </tr> </thead> <tbody> <tr> <td>8 bpp</td> <td>50</td> </tr> <tr> <td>9 bpp</td> <td>30</td> </tr> <tr> <td>10 bpp</td> <td>30</td> </tr> </tbody> </table> <p><b>External Trigger:</b> 20 <math>\mu</math>s to 1 second</p>	Bit Depth	overhead	8 bpp	50	9 bpp	30	10 bpp	30
Bit Depth	overhead								
8 bpp	50								
9 bpp	30								
10 bpp	30								
Notes	Sets the exposure time (in microseconds) when the <i>ExposureMode</i> feature is set to <i>Timed</i> .								
<b>Name</b>	<b>GainSelector</b>								
Display Name	<b>Exposure Mode</b>								
Name Space	SFNC								
Firmware Release	00								
Visibility	Beginner								
Access	Read-Write								
Type	Enumeration								
Values	<p><i>AnalogAll</i> - Apply fine gain adjustment to all analog taps  <i>AnalogAllRaw1</i> – Same as <i>AnalogAll</i> expressed in the sensor's native format  <i>AnalogAllRaw2</i> –Apply coarse gain adjustment to all analog taps (may require FFC recalibration)  <i>DigitalAll</i> - Apply gain adjustment to all digital channels or taps.  <i>DigitalRed</i> -[color only] Apply gain adjustment to digital red channel.  <i>DigitalBlue</i> -[color only] Apply gain adjustment to digital blue channel.  <i>DigitalGreenBlue</i> -[color only] Apply gain adjustment to digital green-blue channel.  <i>DigitalGreenRed</i> -[color only] Apply gain adjustment to digital green-red channel</p>								
Notes	Selects which gain is controlled when adjusting gain features.								
<b>Name</b>	<b>Gain</b>								
Display Name	<b>Gain</b>								
Name Space	SFNC								
Firmware Release	00								
Visibility	Beginner								
Access	Read-Write (Read-only when <i>TriggerMode</i> equals <i>On</i> )								
Type	Float								
Values	0.001x to 8x (for digital), 1x to ~ 1.4x (for analog gain)								
Notes	<p>Specifies the gain in terms of a multiplication factor.</p> <p>For the color cameras, the camera stores color gain values for each <i>pixelSizeInput</i> value. For example, the red gain for 8 <i>bpp</i> can be different than the red gain for 10 <i>bpp</i>. This is to accommodate the way the gain (i.e. PRNU) coefficients are calibrated in flat field correction. For both color and monochrome cameras, the camera stores an analog gain value for each <i>pixelSizeInput</i> value.</p>								

<b>Name</b>	<b>BlackLevelSelector</b>
Display Name	<b>Black Level Selector</b>
Name Space	SFNC
Firmware Release	00
Visibility	Beginner
Access	Read-Write
Type	Enumeration
Values	<i>DigitalAll1</i> [Digital Before FFC] – Global FPN. Apply black level adjustment to all digital channels or taps, before flat field correction. <i>DigitalAll2</i> [Digital After FFC] – Background Subtract. Apply black level adjustment to all digital channels or taps, after flat field correction. <i>AnalogAll1</i> [All analog channels] - Apply black level adjustment to all analog taps.
Notes	Selects which black level (i.e. dark offset) is controlled when adjusting the black level feature.
<b>Name</b>	<b>BlackLevel</b>
Display Name	<b>Black Level</b>
Name Space	SFNC
Firmware Release	00
Visibility	Beginner
Access	Read-Write (Read-only when TriggerMode equals "On")
Type	Integer
Values	For "Digital Before FFC": -DigitalOffsetReference to (255-DigitalOffsetReference), where DigitalOffsetReference is factory calibrated "zero" value. For "Digital After FFC": 0 to 1023 For "All Analog Channels": 0 to 1023-AnalogOffsetReference), where analog offset reference is a factory calibrated "zero" value.
Notes	Specifies the offset in ADC units. The camera stores an analog black level value for each pixelSizeInput value. For example, the analog black level may change when changing the pixelSizeInput feature from 8 bpp to 9 bpp.
<b>Name</b>	<b>pixelSizeInput</b>
Display Name	<b>Input Pixel Size</b>
Name Space	DFNC
Firmware Release	00
Visibility	Beginner
Access	Read-Write
Type	Enumeration
Values	<i>Bpp8</i> [8 BPP] - The sensor digitizes at 8 bits per pixel. <i>Bpp9</i> [9 BPP] - The sensor digitizes at 9 bits per pixel. <i>Bpp10</i> [10 BPP] - The sensor digitizes at 10 bits per pixel.
Notes	Specifies the size of the pixel that is output by the sensor.
<b>Name</b>	<b>sensorResolutionAspectRatio</b>
Display Name	<b>Sensor Aspect Ratio</b>
Name Space	DFNC
Firmware Release	00
Visibility	Beginner
Access	Read-Write
Type	Enumeration
Values	<i>Aspect4to3</i> [4:3 Aspect Ratio] - The aspect ratio (x:y) of the sensor is 4:3. <i>Aspect1to1</i> [1:1 Aspect Ratio] - The aspect ratio (x:y) of the sensor is 1:1.
Notes	Changing this value will cause the following features to update: - <i>SensorWidth</i> , <i>SensorHeight</i> - <i>OffsetX</i> , <i>OffsetY</i> , <i>Width</i> , <i>Height</i> - <i>multipleA OICount</i> , <i>multipleA OISelector</i> , <i>multipleA OIOffsetX</i> , <i>multipleA OIOffsetY</i> , <i>multipleA OIWidth</i> , <i>multipleA OIHeight</i>

<b>Name</b>	<b>sensorAntiBleedingValue</b>
Display Name	<b>Anti-blooming Value</b>
Name Space	Custom
Firmware Release	05
Visibility	Guru
Access	Read-Write
Type	Integer
Values	0 - 65535
Notes	This feature should only be used by experts and is normally set to the factory calibrated default. Changing this value may result in unexpected image artefacts.
<b>Name</b>	<b>sensorExposureControlMode</b>
Display Name	<b>Exposure Control Mode</b>
Name Space	Custom
Firmware Release	05
Visibility	Guru
Access	Read-Write
Type	Enumeration
Values	<i>Off</i> – Exposure control is on <i>On</i> – Exposure control is off
Notes	This feature should only be used by experts and is normally set to <i>On</i> . If turned off the exposure time is determined by the frame period. Changing this value may result in unexpected image artefacts.
<b>Name</b>	<b>sensorGlobalRowResetMode</b>
Display Name	<b>Global Row Reset Mode</b>
Name Space	Custom
Firmware Release	05
Visibility	Guru
Access	Read-Write
Type	Enumeration
Values	<i>Off</i> – Global row reset is off <i>On</i> – Global row reset is on
Notes	This feature should only be used by experts and is normally set to <i>On</i> . Changing this value may result in unexpected image artefacts.
<b>Name</b>	<b>sensorFirstFrameClearMode</b>
Display Name	<b>Clear first frame</b>
Name Space	Custom
Firmware Release	06
Visibility	Guru
Access	Read-Write
Type	Enumeration
Values	Off – No Extra First Frame Clear On – Extra first frame clear applied
Notes	This feature controls whether or not to boost the first frame clear function. The first frame clear is designed to reduce charge that accumulates on the sensor when the camera is idle.  While this feature boosts functionality it also has the potential to introduce additional artefacts to the image. This feature should only be used by experts and is normally set to <i>Off</i> . Changing this value may cause unexpected image artefacts.

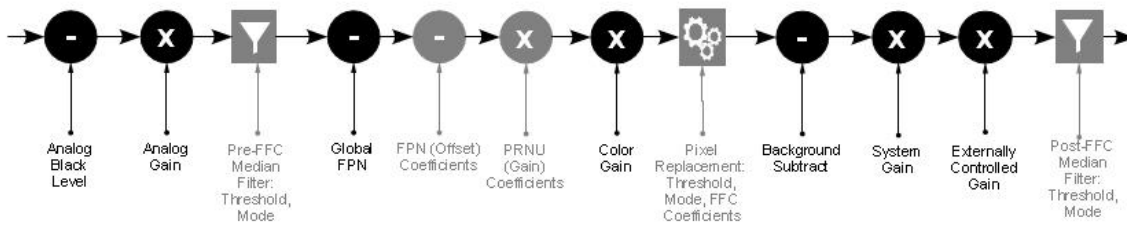
<b>Name</b>	<b>sensorPRPTime</b>
Display Name	<b>PR Pulsing Time</b>
Name Space	Custom
Firmware Release	06
Visibility	Guru
Access	Read-Write
Type	Float
Values	$0 \text{ to } 4.3 \times 10^7$
Notes	This feature should only be used by experts and is normally set to 9.99. Changing this value may cause unexpected image artefacts.

## Invisible Features

<b>Name</b>	<b>streamingPixelSizeInputSelector</b>
Name Space	Custom
Firmware Release	05
Visibility	Invisible
Access	Read-Write
Notes	Hidden register to support feature streaming.
<b>Name</b>	<b>streamingPixelSizeInput</b>
Name Space	Custom
Firmware Release	05
Visibility	Invisible
Access	Read-Write
Notes	Hidden register to support feature streaming.
<b>Name</b>	<b>streamingPixelSizeInputSelector</b>
Name Space	Custom
Firmware Release	05
Visibility	Invisible
Access	Read-Write
Notes	Hidden register to support feature streaming.
<b>Name</b>	<b>streamingAspectRatioSelector</b>
Name Space	Custom
Firmware Release	05
Visibility	Invisible
Access	Read-Write
Notes	Hidden register to support feature streaming.
<b>Name</b>	<b>streamingAspectRatio</b>
Name Space	Custom
Firmware Release	05
Visibility	Invisible
Access	Read-Write
Notes	Hidden register to support feature streaming.

## Gain and Black Level Control Details

The Falcon2 series of cameras provide gain and black level adjustments. Depending on the model of camera, adjustments are available at the sensor as an analog variable and / or in the digital domain. The gain and black level controls can make small compensations to the acquisition in situations where lighting varies and the lens iris cannot be easily adjusted. Optimal gain and black level adjustments maximizes the Falcon2 dynamic range for individual imaging situations. The user can evaluate Gain and Black Level by using CamExpert.



Features and limitations are described below.

- **Analog Black Level** offset is expressed as a digital number providing a  $\pm$  offset from the factory setting. The factory setting optimized the black level offset for maximum dynamic range under controlled ideal dark conditions.
- **Analog Gain** is expressed as a multiplication factor applied at the sensor level, before any FFC. The increased gain increases the sensor's dynamic range but with a non-proportional increase in noise.
- **Global FPN** provides a constant component to the FPN Coefficients. This value is calibrated in the factory but it can be adjusted relative to the factory setting. See the *BlackLevel* register's *DigitalAll1*[Digital Before FFC] option.
- **Color Gain** (Color cameras only) is expressed as a multiplication factor applied after the Analog Gain and any FFC stages. The camera stores a color gain value for each color in the Bayer pattern (Red, Green-Red, Green-Blue and Blue) at each input bit depth (8 bpp, 9 bpp, 10 bpp). This is to accommodate the PRNU FFC calibration.
- **Background Subtract** is a digital number that is used to reduce the baseline pixel value. When combined with the system gain, this value is used to increase contrast in the final output. See the *BlackLevel* register's *DigitalAll2*[Digital After FFC] option.
- **System (Digital) Gain** is expressed as a multiplication factor applied after the Analog Gain and any FFC stages. When combined with the background subtract, this value is used to increase contrast in the final output.
- **Externally Controlled Gain** the camera can be set up to apply a (2x, 4x, 8x) gain that is controlled by external input signals. For example, this allows the user to control digital gain (in factors of 2) on a frame-by-frame basis. See

- [I/O Control Category](#) for more information.

## Set Aspect Ratio

The 4M and 8M models of the Falcon2 camera provide the user with the ability to switch between a 1 : 1 and a 4 : 3 sensor aspect ratio (sensor width vs. height (x : y)). Each aspect ratio maintains its own area of interest (AOI); therefore, switching back and forth will not change the AOI for a given aspect ratio. Additionally, the Aspect Ratios are centered on the same point so switching will not cause the image to move significantly.

## Pixel Digitization Bit Depth

The Falcon2 camera allows the user to control the size of the pixel that is digitized by the sensor in bits per pixel (i.e. 8, 9 or 10 bpp). The pixel size (*pixelSizeInput*) affects the values of the analog gain, analog black level, factory calibrated FFC, and color gain. Note that this is different than the *PixelFormat* which defines the size of the pixel that is output from the camera. Generally increasing the bpp value will result in a lower maximum frame rate but better dark noise performance and dynamic range.

## Exposure Controls

Exposure Control modes define the method and timing of how to control the sensor integration period. The integration period is the amount of time the sensor is exposed to incoming light before the video frame data is transmitted to the controlling computer.

- Exposure control is defined as the start of exposure and exposure duration.
- The start of exposure can be an internal timer signal (free-running mode), an external trigger signal, or a software function call trigger.
- The exposure duration can be programmable (such as the case of an internal timer) or controlled by the external trigger pulse width.

The Falcon2 camera can grab images in one of three ways. The three imaging modes are determined using a combination of the Exposure Mode parameters (including I/ O parameters), Exposure Time and Frame Rate parameters.

Description	Frame Rate	Exposure Time	Trigger Source
Internal frame rate and exposure time	Internal, programmable	Internal programmable	Internal
External frame rate and exposure time	Controlled by external pulse	External	External
EXSYNC pulse controlling the frame rate. Programmed exposure time.	Controlled by external pulse	Internal programmable	External

Figure 12: Exposure controls

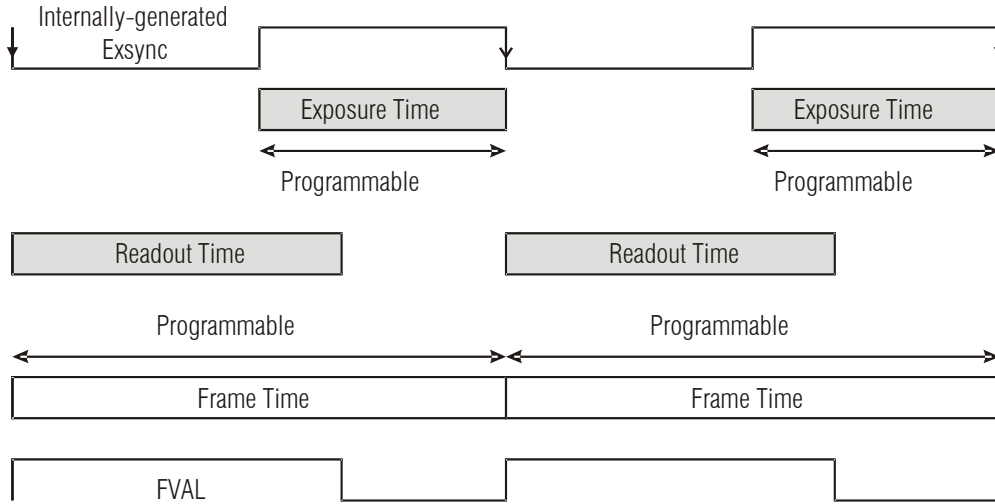
### Internally Programmable Frame Rate and Internally Programmable Exposure Time (Default)

Frame rate is the dominant factor when adjusting the frame rate or exposure time. When setting the frame rate, exposure time will decrease, if necessary, to accommodate the new frame rate. When adjusting the exposure time the range is limited by the frame rate.

**Note:** The camera will not set frame periods shorter than the readout period.

**Camera Features:**

- **TriggerMode = Off**
- **AcquisitionFrameRate = 30 (for example)**
- **ExposureMode = Timed**
- **ExposureTime = 10000 (for example)**



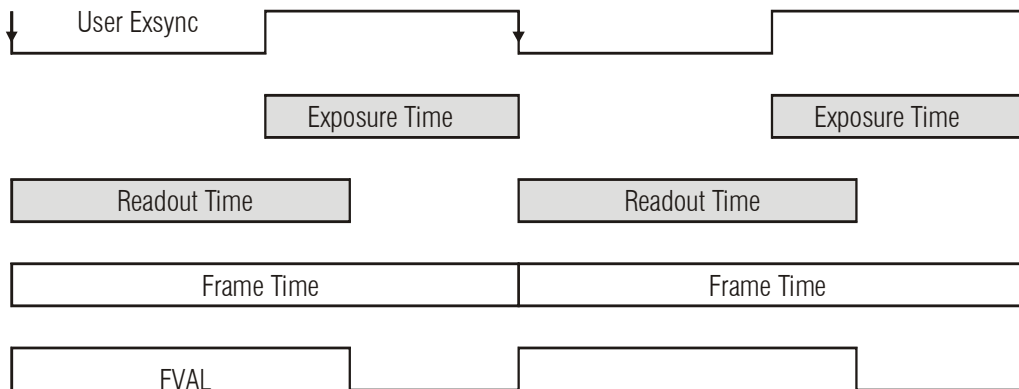
**Figure 13: Internally Programmable Frame Rate and Internally Programmable Exposure Time (Default)**

**External Frame Rate and External Exposure Time (Trigger Width)**

In this mode, EXSYNC sets both the frame period and the exposure time. The rising edge of EXSYNC marks the beginning of the exposure and the falling edge initiates readout.

**Camera Features:**

- **TriggerMode = On**
- **ExposureMode = Trigger Width**



**Figure 14: External Frame Rate and External Exposure Time (Trigger Width)**

## External Frame Rate, Programmable Exposure Time

In this mode, the frame rate is set externally with the falling edge of EXSYNC generating the rising edge of a programmable exposure time.

### Camera Features:

- **TriggerMode = On**
- **ExposureMode = Timed**
- **ExposureTime = 10000 (for example)**

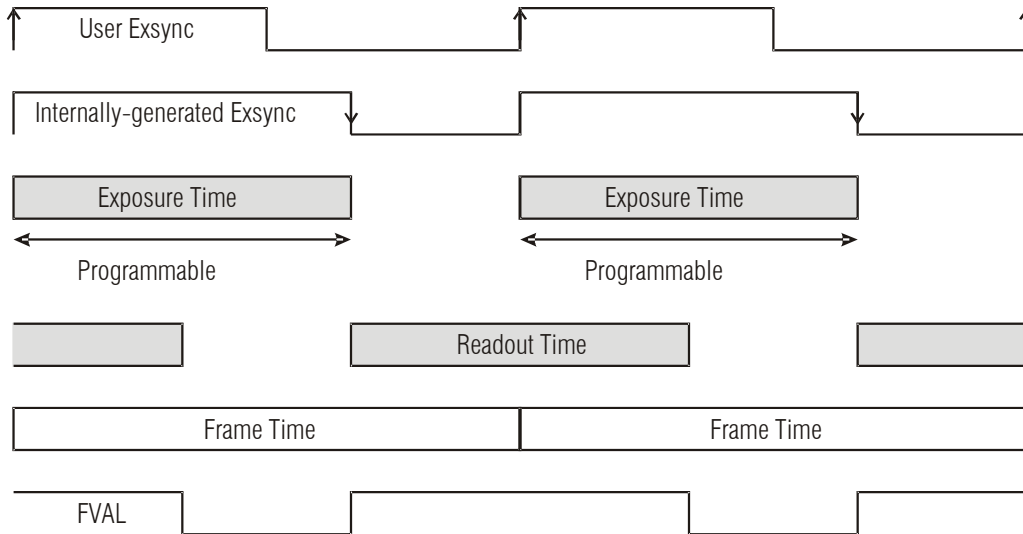


Figure 15: External Frame Rate, Programmable Exposure Time

## Exposure Time

Exposure time is the amount of time that the sensor is allowed to accumulate charge before being read. The user can set the exposure time when the *ExposureMode* feature is set to *Timed*. The limitations on the maximum exposure time are listed below:

- External Exposure Time: 20  $\mu$ s (min) to 1 second (max).
- Internal Exposure Time:  $(1 / \text{frame rate}) - X$

Table 7: Exposure time padding

Pixel Size	Value of "X"
8 bits per pixel	50
9 bits per pixel	30
10 bits per pixel	30

Note: The maximum exposure time is dependent on the frame rate. To increase maximum exposure time, decrease the frame rate.



## Internal Frame Rate

The frame rate is dependent on the window size, and the exposure times are dependent on the frame rate. For example, decreasing the frame rate allows for a longer exposure time. To increase the frame rate decrease the window size. Frame rate takes priority over exposure time. Maximum exposure time can be increased by lowering frame rate.

Faster frame rates can be achieved using by decreasing the number of horizontal pixels (x, columns) and / or the number of vertical lines (y, rows).

The following chart shows maximum camera speed in fps for different combinations of resolutions aspect ratios and sensor bit depths (input pixel size).

In addition, an online frame rate calculator is available from the Falcon2 product page on the Teledyne DALSA site, [here](#).

**Table 8 Maximum Frame rate for 10 Tap Cameralink Configuration**

Resolution	Aspect Ratio	Maximum Column	Maximum Rows	Frame Rate (8 Bit Pixel Size)	Frame Rate (9 Bit Pixel Size)	Frame Rate (10 Bit Pixel Size)
12M	4:3	4096	3072	58	58	58
8M	1:1	2816	2816	90	89	66
8M	4:3	3328	2502	86	86	74
4M	1:1	2048	2048	148	122	91
4M	4:3	2432	1728	168	145	108

**Table 9 Maximum Frame Rate for 8 Tap Cameralink Configuration**

Resolution	Aspect Ratio	Maximum Column	Maximum Rows	Frame Rate (8 Bit Pixel Size)	Frame Rate (9 Bit Pixel Size)	Frame Rate (10 Bit Pixel Size)
12M	4:3	4096	3072	46	46	46
8M	1:1	2816	2816	75	74	57
8M	4:3	3328	2502	71	71	63
4M	1:1	2048	2048	137	122	91
4M	4:3	2432	1728	140	132	101

# I/O Control Category

The Falcon2 I/O controls, as shown by CamExpert, groups features used to configure external inputs and acquisition actions based on those inputs, plus camera output signals to other devices. Parameters in gray are read only, either always or due to another parameter being disabled. Parameters in black are user set in CamExpert or programmable via an imaging application.

Features listed in the description table but tagged as *Invisible* are usually for Teledyne DALSA or third party software usage—not typically needed by end user applications.

Category	Parameter	Value
Camera Information	Trigger Selector	FrameStart
Sensor Control	Trigger Mode	On
I/O Controls	Trigger Source	Software
Advanced Processing	Software Trigger	Press...
Image Format Controls	Trigger Overlap	Off
CameraLink Transport Layer	Trigger Delay	0
Serial Port Control	Line Selector	CC1
File Access Control	Line Mode	Input
	Line Name	Input 1
	Line Pinout	C1_Pin22Pos_Pin9Neg
	Line Detection Level	Threshold_2_4
	Line Debouncing Period	1
	Line Inverter	True
	Line Status	False
	Line Status All	15
	Output Line Source	Off
	Output Line Pulse Dela...	0
	Output Line Pulse Dura...	1000
	Output Line Software L...	Not Enabled
	Output Line Value	Not Enabled
	Output Line Software ...	Not Enabled
	External Gain Mode	Off
	External Gain Polarity	Sample Falling
	External Gain Sample S...	Line 1
	External Gain LSB Source	Line 1
	External Gain MSB Source	Line 1
	<< Less	

Figure 16: I / O Category in CamExpert

## Event Control Feature Descriptions

The following table describes these parameters along with their view attribute and minimum camera firmware version required. Additionally, the table will indicate which parameter is a member of the DALSA Features Naming Convention (DFNC), versus the GenICam Standard Features Naming Convention

<b>Name</b>	<b>TriggerSelector</b>
Display Name	<b>Trigger Selector</b>
Name Space	SFNC
Firmware Version	00
Visibility	Beginner
Access	Read-Only
Type	Enumeration
Values	FrameStart
<b>Name</b>	<b>TriggerMode</b>
Display Name	<b>Trigger Mode</b>
Name Space	SFNC
Firmware Release	00
Visibility	Beginner
Access	Read-Write
Type	Enumeration
Values	On – Use external trigger. Off - Use internal trigger.
Notes	Enables and disables external frame trigger.
<b>Name</b>	<b>TriggerSource</b>
Display Name	<b>Trigger Source</b>
Name Space	SFNC
Firmware Release	00
Visibility	Beginner
Access	Read-Write
Type	Enumeration
Values	CC1 – Cameralink Control Line 1 CC2– Cameralink Control Line 2 CC3– Cameralink Control Line 2 CC4– Cameralink Control Line 2 Line1 – General Purpose Input Line 1 Line2– General Purpose Input Line 1 Software- Software trigger
Notes	Specifies the internal signal or input line to use as the trigger source. The trigger mode must be set to On.
<b>Name</b>	<b>TriggerSoftware</b>
Display Name	<b>Trigger Software</b>
Name Space	SFNC
Firmware Release	00
Visibility	Beginner
Access	Read-Write
Type	Command
Notes	Generate an internal trigger. Available when the trigger mode is enabled and the trigger source is equal to 'Software'.

<b>Name</b>	<b>TriggerOverlap</b>
Display Name	<b>Trigger Overlap</b>
Name Space	SFNC
Firmware Release	00
Visibility	Beginner
Access	Read-Only
Type	Enumeration
Values	Off – No Trigger overlap is allowed.
Notes	Specify the type of trigger overlap permitted with the previous frame. This feature defines when a valid trigger will be accepted (or latched) for a new frame.
<b>Name</b>	<b>TriggerDelay</b>
Name Space	<b>Trigger Delay</b>
Firmware Release	SFNC
Visibility	00
Access	Beginner
Type	Float
Units	$\mu$ s
Values	0 - 281474976710655 $\mu$ s
Notes	Specifies the delay in microseconds ( $\mu$ s) to apply after the trigger reception before activating it.
<b>Name</b>	<b>LineSelector</b>
Display Name	<b>Line Selector</b>
Name Space	SFNC
Firmware Release	00
Visibility	Beginner
Access	Read-Write
Type	Enumeration
Values	CC1, CC2, CC3, CC4 – Cameralink Camera Control Line 1, 2, 3, or 4 Line1, Line2 - General Purpose Input 1 or 2 Line3, Line4 - General Purpose Output 1 or 2
Notes	Selects the logical line of the device to configure.
<b>Name</b>	<b>LineMode</b>
Display Name	<b>Line Mode</b>
Name Space	SFNC
Firmware Release	00
Visibility	Beginner
Access	Read-Only
Type	Enumeration
Values	Input – the line is an input Output – the line is an output
Notes	Specifies if the selected physical pin is used as an input or output signal.
<b>Name</b>	<b>lineName</b>
Display Name	<b>Line Name</b>
Name Space	DFNC
Firmware Release	00
Visibility	Beginner
Access	Read-Only
Type	Enumeration
Values	Input 1, Input 2, Input 3, Input 4, Input 5, Input 6 Output 1, Output 2
Notes	Description of the physical pin associate with the logical line.

<b>Name</b>	<b>linePinAssociation</b>
Display Name	<b>Line Pinout</b>
Name Space	DFNC
Firmware Release	00
Visibility	Beginner
Access	Read-Only
Type	Enumeration
Values	H1_Pin6Pos_Pin5Neg, H1_Pin11Pos_Pin12Neg, H1_Pin3_Pin4, H1_Pin7_Pin8 C1_Pin22Pos_Pin9Neg, C1_Pin10Pos_Pin23Neg, C1_Pin24Pos_Pin11Neg, C1_Pin12Pos_Pin25Neg  The H1 prefix refers to the Hirose Power and input cable (See Figure 7) while the C1 refers to the Cameralink 1 connector( See Figure 37 )
Notes	Physical pin location associated with the logical line.
<b>Name</b>	<b>lineDetectionLevel</b>
Display Name	<b>Line Detection Level</b>
Name Space	DFNC
Firmware Release	00
Visibility	Beginner
Access	Read-Write
Type	Enumeration
Values	Threshold_2_4 - [2.4V] – for TTL inputs Threshold_6_0- [ 6V] – for 12 V input Threshold_12_0 – [12V] – for 24 V input
Notes	The voltage at which the signal is treated as a logical high. Available when the Line selector is set to a general purpose input (GPI).  Note: This value is for both general purpose inputs (i.e. setting this value sets it for both Line 1 and Line 2).
<b>Name</b>	<b>lineDebouncingPeriod</b>
Display Name	<b>Line Debouncing Period</b>
Name Space	DFNC
Firmware Release	00
Visibility	Beginner
Access	Read-Write
Type	Enumeration
	µs
Values	1 to 255 µs
Notes	Specifies the minimum length of an input line voltage transition before recognizing a signal transition. Available when the Line selector is set to an input. Each input line stores its own debouncing period.
<b>Name</b>	<b>LineInverter</b>
Display Name	<b>Line Inverter</b>
Name Space	SFNC
Firmware Release	00
Visibility	Beginner
Access	Read-Write
Type	Boolean
Values	True – invert signal False – don't invert signal
Notes	Controls whether to invert the selected input or output line signal.

<b>Name</b>	<b>LineStatus</b>																
Display Name	<b>Line Status</b>																
Name Space	SFNC																
Firmware Release	00																
Visibility	Beginner																
Access	Read-Only																
Type	Boolean																
Values	True – the selected signal is high False – the selected signal is low																
Notes	Returns the current status of the selected input or output line. This is a polled feature that requires the host to poll the camera for the latest value.																
<b>Name</b>	<b>LineStatusAll</b>																
Display Name	<b>Line Status All</b>																
Name Space	SFNC																
Firmware Release	00																
Visibility	Beginner																
Access	Read-Only																
Type	Integer																
Values	The order is Line1(LSB), Line2, Line3, Line4, CC1, CC2, ...  <table border="1" style="margin-left: auto; margin-right: auto;"> <thead> <tr> <th>7</th> <th>6</th> <th>5</th> <th>4</th> <th>3</th> <th>2</th> <th>1</th> <th>0</th> </tr> </thead> <tbody> <tr> <td>CC4(MSB)</td> <td>CC3</td> <td>CC2</td> <td>CC1</td> <td>Line 4</td> <td>Line 3</td> <td>Line 2</td> <td>Line 1(LSB)</td> </tr> </tbody> </table>	7	6	5	4	3	2	1	0	CC4(MSB)	CC3	CC2	CC1	Line 4	Line 3	Line 2	Line 1(LSB)
7	6	5	4	3	2	1	0										
CC4(MSB)	CC3	CC2	CC1	Line 4	Line 3	Line 2	Line 1(LSB)										
Notes	Returns the current status of all available line signals, at time of polling, in a single bitfield. This is a polled feature that requires the host to poll the camera for the latest value.																
<b>Name</b>	<b>outputLineSource</b>																
Display Name	<b>Output Line Source</b>																
Name Space	DFNC																
Firmware Release	00																
Visibility	Beginner																
Access	Read-Write																
Type	Enumeration																
Values	<i>Off</i> – The output line is open <i>SoftwareControlled</i> – The value of the output line is determined by <i>outputLineValue</i> , <i>outputLineSoftwareLatchControl</i> and/ or <i>outputLineSoftwareCmd</i> . <i>PulseOnStartofInternalEXSYNC</i> – Generate pulse on start of EXSYNC signal to sensor <i>PulseOnEndofInternalEXSYNC</i> – Generate pulse on end of EXSYNC signal to sensor <i>PulseOnStartofExposure</i> – Generate a pulse when the sensor actually starts exposing its pixels. (Slight delay after EXSYNC) <i>PulseOnEndofExposure</i> – Generate a pulse when the sensor stops exposing its pixels <i>PulseOnStartofReadout</i> – Generate a pulse when the sensor starts reading its pixels <i>PulseOnEndofReadout</i> – Generate a pulse when the sensor stops reading its pixels <i>PulseOnStartOfLineActive</i> – Generate a pulse when the Line Valid (LVAL) from the sensor goes active <i>PulseOnInput1</i> – Generate a pulse when the CC1 goes active <i>PulseOnInput2</i> – Generate a pulse when the CC2 goes active <i>PulseOnInput3</i> – Generate a pulse when the CC3 goes active <i>PulseOnInput4</i> – Generate a pulse when the CC4 goes active <i>PulseOnInput5</i> – Generate a pulse when the General Purpose Input 1 goes active <i>PulseOnInput6</i> – Generate a pulse when the General Purpose Input 2 goes active <i>PulseOnEndOfLineActive</i> – Generate a pulse when the Line Valid (LVAL) from the sensor goes inactive																
Notes	Selects which internal signal or software control state to output on the selected line. The pulse is defined by <i>outputLinePulseDelay</i> and <i>outputLinePulseDuration</i> .  Note: the <i>LineMode</i> feature must be set to <i>Output</i> .																

<b>Name</b>	<b>outputLinePulseDelay</b>
Display Name	<b>Output Line Pulse Delay</b>
Name Space	DFNC
Firmware Release	00
Visibility	Beginner
Access	Read-Write
Type	Integer
Units	µs
Values	0 to 8388608 µs
Notes	Sets the delay before the output line pulse duration is output.  <i>Note: LineMode feature must be set to Output and outputLineSource is not equal to Off or SoftwareControlled.</i>
<b>Name</b>	<b>outputLinePulseDuration</b>
Display Name	<b>Output Line Pulse Duration</b>
Name Space	DFNC
Firmware Release	00
Visibility	Beginner
Access	Read-Write
Type	Integer
Units	µs
Values	0 to 8388608 µs
Notes	Sets the duration of the output pulse.  <i>Note: LineMode feature must be set to Output and outputLineSource is not equal to Off or SoftwareControlled.</i>
<b>Name</b>	<b>outputLineSoftwareLatchControl</b>
Display Name	<b>Output Line Software Latch Control</b>
Name Space	DFNC
Firmware Release	00
Visibility	Beginner
Access	Read-Write
Type	Enumeration
Values	<i>Off</i> – changes to the output line value are applied immediately. <i>Latch</i> – changes to the output line value are applied when the Output Line Software Command is triggered.
Notes	The software latch allows the user to set more than 1 output simultaneously  <i>OutputLine</i> that are currently in Software Latch control will only set with the value in <i>OutputLineValue</i> with the <i>outputLineSoftwareCmd</i> feature.
<b>Name</b>	<b>outputLineValue</b>
Display Name	<b>Output Line Value</b>
Name Space	DFNC
Firmware Release	00
Visibility	Beginner
Access	Read-Write
Type	Enumeration
Values	<i>Active</i> - Sets the Output circuit to close. <i>Inactive</i> - Sets the Output circuit to open.
Notes	Selects the state of the output on the selected line. The Value will be applied immediately if the <i>outputLineSoftwareLatchControl</i> feature is equal to OFF.  The Value will be applied when the <i>outputLineSoftwareCmd</i> feature is set if the <i>outputLineSoftwareLatchControl</i> feature is equal to LATCH.  <i>Note: LineMode feature must be set to Output and outputLineSource is set SoftwareControlled.</i>

<b>Name</b>	<b>outputLineSoftwareCmd</b>										
Display Name	<b>Output Line Software Command</b>										
Name Space	DFNC										
Firmware Release	00										
Visibility	Beginner										
Access	Read-Write										
Type	Integer										
Values	0 to 3										
Notes	<p>Contains a bit field representing whether to apply to cached <i>outputLineValue</i> values.</p> <table border="1" data-bbox="620 489 1269 674"> <thead> <tr> <th>Value</th> <th></th> </tr> </thead> <tbody> <tr> <td>0</td> <td>Don't apply any value</td> </tr> <tr> <td>1</td> <td>Apply <i>outputLineValue</i> of <i>Output1</i></td> </tr> <tr> <td>2</td> <td>Apply <i>outputLineValue</i> of <i>Output2</i></td> </tr> <tr> <td>3</td> <td>Apply <i>outputLineValue</i> of <i>Output1</i> and <i>Output2</i></td> </tr> </tbody> </table> <p>Note: <i>LineMode</i> feature must be set to <i>Output</i> and <i>outputLineSource</i> is set <i>SoftwareControlled</i>.</p>	Value		0	Don't apply any value	1	Apply <i>outputLineValue</i> of <i>Output1</i>	2	Apply <i>outputLineValue</i> of <i>Output2</i>	3	Apply <i>outputLineValue</i> of <i>Output1</i> and <i>Output2</i>
Value											
0	Don't apply any value										
1	Apply <i>outputLineValue</i> of <i>Output1</i>										
2	Apply <i>outputLineValue</i> of <i>Output2</i>										
3	Apply <i>outputLineValue</i> of <i>Output1</i> and <i>Output2</i>										
<b>Name</b>	<b>externalControlledGainMode</b>										
Display Name	<b>External Gain Mode</b>										
Name Space	Custom										
Firmware Release	05										
Visibility	Beginner										
Access	Read-Write										
Type	Enumeration										
Values	Off – disable external line controlled gain On – enable external line controlled gain										
Notes	Enables and disables the gain that is controlled by the digital input lines										
<b>Name</b>	<b>externalControlledGainLineActivation</b>										
Display Name	<b>External Gain Line Activation</b>										
Name Space	Custom										
Firmware Release	05										
Visibility	Beginner										
Access	Read-Write										
Type	Enumeration										
Values	FallingEdge – Sample when the source goes low RisingEdge – Sample when the source goes high										
Notes	Specifies the signal transition on the source line ( <i>externalControlledGainSampleSource</i> ) that causes the gain to be sampled.										
<b>Name</b>	<b>externalControlledGainSampleSource</b>										
Display Name	<b>External Gain Sample Source</b>										
Name Space	Custom										
Firmware Release	05										
Visibility	Beginner										
Access	Read-Write										
Type	Enumeration										
Values	CC1, CC2, CC3,CC4, Line1, Line2										
Notes	Use the selected line to trigger gain sampling. The sampling occurs on the rising or falling edge of the signal. This is determined by <i>externalControlledGainLineActivation</i> .										



<b>Name</b>	<b>externalControlledGainMSBSource, externalControlledGainLSBSource</b>															
Display Name	<b>External Gain [LSB/MSB] Source</b>															
Name Space	Custom															
Firmware Release	05															
Visibility	Beginner															
Access	Read-Write															
Type	Enumeration															
Values	CC1, CC2, CC3,CC4, Line1, Line2															
Notes	Specifies the most and least significant bits that define the externally controlled gain factor. <div style="text-align: center; margin: 10px 0;"> <table border="1"> <thead> <tr> <th>MSB</th> <th>LSB</th> <th>Gain Factor</th> </tr> </thead> <tbody> <tr> <td>0</td> <td>0</td> <td>1x</td> </tr> <tr> <td>0</td> <td>1</td> <td>2x</td> </tr> <tr> <td>1</td> <td>0</td> <td>4x</td> </tr> <tr> <td>1</td> <td>1</td> <td>8x</td> </tr> </tbody> </table> </div>	MSB	LSB	Gain Factor	0	0	1x	0	1	2x	1	0	4x	1	1	8x
MSB	LSB	Gain Factor														
0	0	1x														
0	1	2x														
1	0	4x														
1	1	8x														

## Invisible Features

<b>Name</b>	<b>streamingGPIOLineSelector</b>
Name Space	Custom
Firmware Release	04
Visibility	Invisible
Notes	Internal use. To implement feature streaming.
<b>Name</b>	<b>streamingGPIO</b>
Name Space	Custom
Firmware Release	04
Visibility	Invisible
Notes	Internal use. To implement feature streaming.
<b>Name</b>	<b>streamingGPOLineSelector</b>
Name Space	Custom
Firmware Release	04
Visibility	Invisible
Notes	Internal use. To implement feature streaming.

## Trigger Modes

The camera's image exposures are initiated by a trigger signal. The trigger event is either a programmable internal signal used in free running mode, an external input used for synchronizing exposures to external triggers, or a programmed function call message by the controlling computer. These triggering modes are described below.

- Free running (trigger disabled): The camera free-running mode has a programmable internal timer for frame rate and a programmable exposure period.
- External trigger: Exposures are controlled by an external trigger signal. The external trigger signal can be either a Camera Link control line (i.e. CC [4 : 1]) or a general purpose input (e.g. GPIO [2 : 1]). General purpose inputs are isolated by an opto-coupler input with a time programmable debounce circuit.
- Software trigger: An exposure trigger is sent as a control command via the Camera Link serial communications interface. Software triggers cannot be considered time accurate due to communications latency and sequential command jitter.

## I/O Block Diagram

The following diagram describes the Input/ Output features of the camera and how they are related.

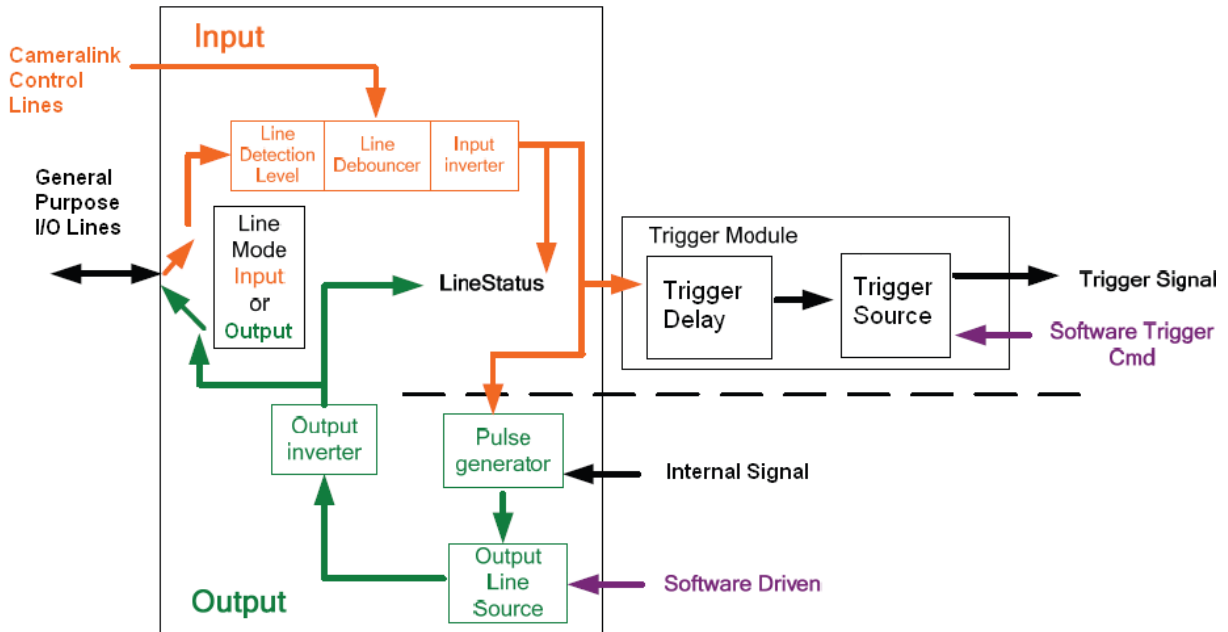


Figure 17 I/O Module Block Diagram

## CameraLink Control Lines

Falcon2 can use the four CameraLink control lines to trigger frames or output pulses. These signals are located in the CameraLink 1 cable (See Appendix A: Camera Link) and bypass the Line detection level.

## Opto-coupled Inputs

Falcon2 provides two sets of Opto-isolated input signals. These can be used as external trigger sources. The signals should be in range from 2.4 V to 24 V, 5 V typical. See *lineDetectionLevel*.

The delay between signals at the I/ O pin and the internal timing core is a function of the signal swing and the typical latency @5V swing is 3.5  $\mu$ s.

Refer to Figure 7: 12-pin Hirose Circular Male Power Plug—Power Connector for the connector pin out and electrical information. The cable shell and shield should electrically connect the camera chassis to the computer chassis for maximum EMI protection.

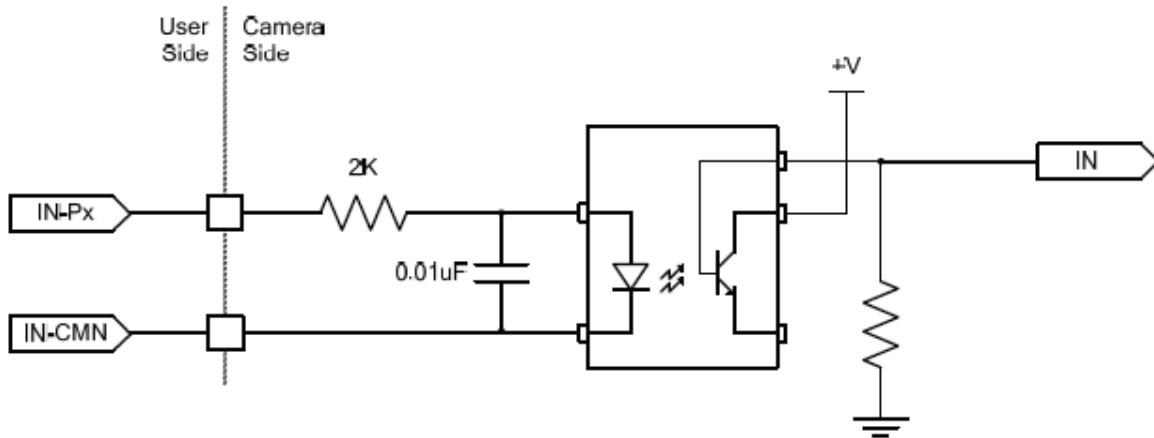


Figure 18 Opto-coupled input

Each input incorporates a signal debounce circuit (following the opto-coupler) to eliminate short noise transitions that could incorrectly be interpreted as a valid pulse. The duration is user programmable from 1  $\mu$ s to 255  $\mu$ s using CamExpert.

## Opto-Coupled Outputs

The outputs are unpowered devices and require external power. The simplified diagram below demonstrates the need for a pull-up resistor when using the outputs.

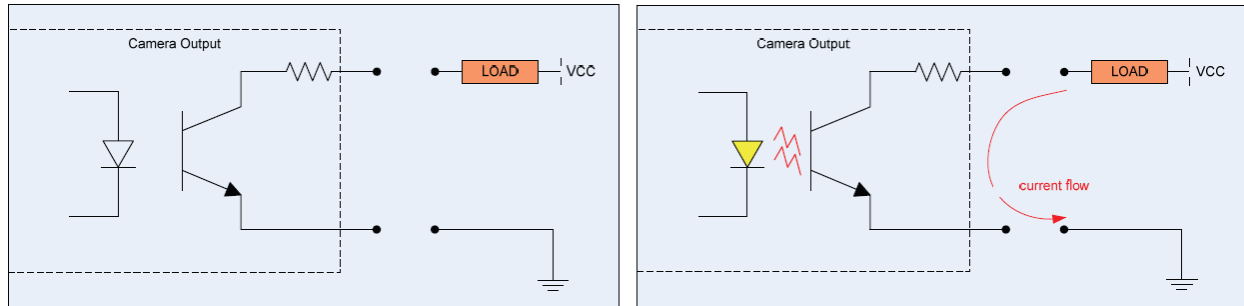


Figure 19: Simplified General Purpose Output Diagram

## Advanced Processing Control Category

The Falcon2 Advanced Processing controls, as shown by CamExpert, groups parameters used to configure Defective Pixel Detection, Flat Field calibration. Parameters in gray are read only, either always or due to another parameter being disabled. Parameters in black are user set in CamExpert or programmable via an imaging application.

Note that the features listed in the description table but tagged as *Invisible* are usually for Teledyne DALSA Support or third party software usage—and not typically required by end-user applications.

Parameters - Visibility: Guru		
Category	Parameter	Value
Camera Information	<b>Correction Mode</b>	<b>Active</b>
Sensor Control	Correction Algorithm	Method 1
I/O Controls	Gain Mode	High Gain
Advanced Processing	Correction Type	Area-Based
Image Format Controls	<b>Current Active Set</b>	<b>User Flat Field 1</b>
CameraLink Transport Layer	Pixel X Coordinate	Not Enabled
Serial Port Control	Pixel Y Coordinate	Not Enabled
File Access Control	Pixel Gain(PRNU)	Not Enabled
	Pixel Offset(FPN)	Not Enabled
	Clear Coefficients	Not Enabled
	Calibration Sample Size	64
	Offset(FPN) Calibration	Not Enabled
	Gain Calibration Target	80.059
	Gain Calibration Mode	High Gain
	Gain(PRNU) Calibration	Not Enabled
	Save Calibration	Not Enabled
	Copy Source	Factory Setting
	Copy Coefficient to Active	Not Enabled
	<b>Pixel Replacement Mode</b>	<b>Off</b>
	Pixel Replacement Threshold	127
	Pixel Replacement Algorithm	Average Adjacent
	Pixel Replacement Calibration	Not Enabled
	Pixel Replacement Calibration Threshold	127
	Hot Pixels Replaced	Not Enabled
	Offset Pixels Clipped	Not Enabled
	Dead Pixels Replaced	Not Enabled
	Gain Clipped Pixels	Not Enabled
	Dynamic Replacement Algorithm	Pre-Correction Median Filter
	Dynamic Replacement Mode	Off
	Dynamic Replacement Min Threshold	0
	Feed Through Correction Apply	Off
	Simple Feedthrough Correction Coeff 1	0
	Simple Feedthrough Correction Coeff 2	0
	Simple Feedthrough Correction Coeff 3	0
	<< Less	

**Figure 20 Advanced Processing Control**

## Advanced Processing Control Feature Descriptions

The following table describes these parameters along with their view attribute and the minimum camera firmware version required.

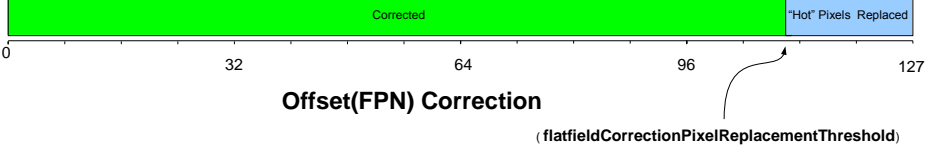
Name	flatfieldCorrectionMode
Display Name	<b>Flat field Correction Mode</b>
Name Space	DFNC
Firmware Release	00
Visibility	Beginner
Access	Read/ Write
Type	Enumeration
Values	<p><i>Off</i> - Flat Field correction disabled</p> <p><i>ActiveAll</i> - FPN and PRNU correction is active</p> <p><i>ActiveFPNOnly</i> - FPN correction is active</p> <p><i>ActivePRNUOnly</i> - PRNU correction is active</p> <p><i>Calibration</i> - The camera is configured to calibration mode(Only available when TriggerMode=Off, flatfielCorrectionCurrenActiveSet is not FactoryFlatfield, and width and height are maximized). The device may automatically adjust some features in the camera when calibration mode is enabled. The features that are automatically adjusted are device specific. The device will not restore these features when the flat field correction mode is changed from calibration mode to another mode. For example, width and height may be set to the maximum sensor size when the flat field calibrate mode is enable.</p>
Notes	Sets the mode for the flatfield correction.
Name	flatfieldCorrectionAlgorithm
Display Name	<b>Flat field Correction Algorithm</b>
Name Space	DFNC
Firmware Release	00
Visibility	Expert
Access	Read Only
Type	Enumeration
Values	<p><i>Method1</i>(monochrome camera)</p> <p><i>Method2</i>(color camera)</p>
Notes	<p>The following formula is used to calculate the flatfield corrected pixel:</p> <p><b>Mono camera:</b></p> $\text{newPixelValue}_{x,y} = (\text{sensorPixelValue}_{x,y} - \text{FFCOffset}_{x,y}) * \text{FFCGain}_{[x y]}$ <p><b>Color camera:</b></p> $\text{newPixelValue}_{x,y} = (\text{sensorPixelValue}_{x,y} - \text{FFCOffset}_{x,y}) * \text{FFCGain}_{x,y} * \text{gain per color}$
Name	flatfieldCorrectionGainMode
Display Name	<b>Gain Correction Mode</b>
Name Space	Custom
Firmware Release	05
Visibility	Expert
Access	Read Only
Type	Enumeration
Values	<p><i>HighGain</i> -The set was calibrated using high gain and lower resolution</p> <p><i>HighResolution</i> - The set was calibrated using high resolution and lower gain</p>
Notes	<p>Displays the flatfield gain mode that will was used in calibration.</p> <ul style="list-style-type: none"> <li>High gain mode can apply a correction gain between 1 and 2 with reduced (9 bit) resolution.</li> <li>High resolution can apply a correction gain between 1 and 1.5 with maximum (10 bit) resolution</li> </ul> <p>Refreshes when flatfieldCorrectionCurrentActiveSet, flatfieldCalibrationPRNU, flatfieldCalibrationClearCoefficient, or flatfieldCoefficientsCopyInCurrent changes.</p>

<b>Name</b>	<b>flatfieldCorrectionType</b>
Display Name	<b>Correction Type</b>
Name Space	DFNC
Firmware Release	00
Visibility	Expert
Access	Read Only
Type	Enumeration
Values	<i>AreaBase</i>
Notes	Flatfield correction is based on an entire image (array).
<b>Name</b>	<b>flatfieldCorrectionCurrentActiveSet</b>
Display Name	<b>Current Active Set</b>
Name Space	DFNC
Firmware Release	00
Visibility	Expert
Access	Read-Write (Read-Only when in Calibration Mode)
Type	Enumeration
Values	<i>FactoryFlatfield</i> - Factory calibrated flat field. This set actual consists of three sets calibrated for a given pixelInputSize. When the pixelInputSize changes, the camera will automatically change the set in use. <i>UserFlatField1</i> to <i>UserFlatField4</i> - User configurable flat field sets. They can only be calibrated to 1 pixelInputSize value.
Notes	Specifies the current set of flat field coefficients to use. This feature cannot be changed while the camera is in flat field calibration mode.
<b>Name</b>	<b>flatfieldCorrectionPixelYCoordinate</b>
Display Name	<b>Pixel Y Coordinate</b>
Name Space	DFNC
Firmware Release	00
Visibility	Expert
Access	Read-Write when in Calibration Mode
Type	Enumeration
Values	1 to <i>SensorHeight</i>
Notes	Vertical Indexer into the array of FFC coefficients.
<b>Name</b>	<b>flatfieldCorrectionPixelXCoordinate</b>
Display Name	<b>Pixel X Coordinate</b>
Name Space	DFNC
Firmware Release	00
Visibility	Expert
Access	Read-Write when in Calibration Mode
Type	Enumeration
Values	1 to <i>SensorWidth</i>
Notes	Horizontal Indexer into the array of FFC coefficients.
<b>Name</b>	<b>flatfieldCorrectionGain</b>
Display Name	<b>Pixel Gain (PRNU)</b>
Name Space	DFNC
Firmware Release	00
Visibility	Beginner
Access	Read-Write when in Calibration Mode
Type	Float
Values	1 to 2 (when flatfieldCorrectionGainMode = <i>HighGain</i> ). 1 to 1.5 (when flatfieldCorrectionGainMode = <i>HighResolution</i> ).
Notes	Sets the gain to apply to the currently selected pixel.

<b>Name</b>	<b>flatfieldCorrectionOffset</b>
Display Name	<b>Pixel Offset(FPN)</b>
Name Space	DFNC
Firmware Release	00
Visibility	Beginner
Access	Read-Write when in Calibration Mode
Type	Integer
Values	0 to 127
Notes	Sets the offset to apply to the currently selected pixel.
<b>Name</b>	<b>flatfieldCalibrationClearCoefficient</b>
Display Name	<b>Clear Coefficients</b>
Name Space	DFNC
Firmware Release	00
Visibility	Expert
Access	Read-Write when in Calibration Mode
Type	Command
Notes	This feature is used to clear all the current FPN and PRNU coefficients in the selected Active Set.
<b>Name</b>	<b>flatfieldCalibrationSampleSize</b>
Display Name	<b>Calibration Sample Size</b>
Name Space	DFNC
Firmware Release	00
Visibility	Beginner
Access	Read-Only
Type	Integer
Values	64
Notes	The number of images to average to perform the calibration.
<b>Name</b>	<b>flatfieldCalibrationFPN</b>
Display Name	<b>Offset(FPN) Calibration</b>
Name Space	DFNC
Firmware Release	00
Visibility	Expert
Access	Read-Write when in Calibration Mode
Type	Command
Notes	Performs fixed pattern noise (FPN) calibration. FPN calibration eliminates fixed pattern noise by subtracting all non-uniformities and dark current to obtain near 0 DN output in the dark (no light exposed to the sensor).
<b>Name</b>	<b>flatfieldCalibrationTarget</b>
Display Name	<b>Gain Calibration Target</b>
Name Space	DFNC
Firmware Release	00
Visibility	Expert
Access	Read-Write when in Calibration Mode
Type	Float
Units	%
Values	0 to 100
Notes	Sets the target pixel value for the gain (PRNU) calibration. It is specified as a percentage of the output range (for example, 1023 DN for 10 bits).

<b>Name</b>	<b>flatfieldCalibrationPRNU</b>
Display Name	<b>Gain(PRNU) Calibration</b>
Name Space	DFNC
Firmware Release	00
Visibility	Expert
Access	Read-Write when in Calibration Mode
Type	Command
Notes	Performs photo response non-uniformity (PRNU) calibration.. PRNU calibration eliminates the difference in responsivity between the most and least sensitive pixel, creating a uniform response to light. See the <a href="#">Gain (PRNU) Calibration</a> section in <a href="#">Appendix D: Internal Flat Field Calibration Algorithms</a> .
<b>Name</b>	<b>flatfieldCalibrationGainMode</b>
Display Name	<b>Gain Calibration Mode</b>
Name Space	Custom
Firmware Release	05
Visibility	Guru
Access	Read-Write when in Calibration Mode
Type	Enumeration
Values	<i>HighGain</i> - Calibrate using high gain and lower resolution <i>HighResolution</i> - Calibrate using high resolution and lower gain
Notes	Selects the flatfield gain mode that will be used in calibration. <ul style="list-style-type: none"> <li>• High gain mode can apply a correction gain between 1 and 2 with reduced resolution.</li> <li>• High resolution can apply a correction gain between 1 and 1.5 with maximum resolution.</li> </ul>
<b>Name</b>	<b>flatfieldCalibrationSave</b>
Display Name	<b>Save Calibration</b>
Name Space	DFNC
Firmware Release	00
Visibility	Expert
Access	Read-Write when in Calibration Mode
Type	Command
Notes	Saves the current flat field coefficients in the Active Set.
<b>Name</b>	<b>flatfieldCoefficientsCopySource</b>
Display Name	<b>Copy Source</b>
Name Space	DFNC
Firmware Release	00
Visibility	Expert
Access	Read-Write when in Calibration Mode
Type	Enumeration
Values	<i>FactoryFlatfield</i> - Factory Calibrated flatfield. <i>UserFlatField1</i> to <i>UserFlatField4</i> - User configurable flat field sets.
Notes	Selects the flatfield coefficients set to copy to the current Active Set
<b>Name</b>	<b>flatfieldCoefficientsCopyInCurrent</b>
Display Name	<b>Copy Coefficient to Active</b>
Name Space	DFNC
Firmware Release	00
Visibility	Expert
Access	Read-Write when in Calibration Mode
Type	Command
Notes	Copies the currently selected flat field coefficients in the Active Set.



<b>Name</b>	<b>flatfieldCorrectionPixelReplacementThreshold</b>
Display Name	<b>Pixel Replacement Threshold</b>
Name Space	Custom
Firmware Release	00
Visibility	Guru
Access	Read-Write
Type	Integer
Values	1 to 127
Notes	<p>The FFC offset value(FPN) above which pixel replacement occurs(See Figure 21). This value can be adjusted to replace more or fewer pixels.</p> <p style="text-align: center;">Flat Field Offset(FPN) Values</p>  <p style="text-align: center;"><b>Offset(FPN) Correction</b> (flatfieldCorrectionPixelReplacementThreshold)</p> <p style="text-align: center;"><b>Figure 21 Pixel Replacement Threshold</b></p>
<b>Name</b>	<b>flatfieldCorrectionPixelReplacementMode</b>
Display Name	<b>Pixel Replacement Mode</b>
Name Space	Custom
Firmware Release	05
Visibility	Expert
Access	Read-Write
Type	Enumeration
Values	<i>Off</i> - Disable pixel replacement <i>Active</i> - Enable defective pixel replacement
Notes	<p>Enable or disable pixel replacement.</p> <p>If Active: If <math>FPN_{x,y} &gt; flatfieldCorrectionPixelReplacementThreshold</math> OR <math>PRNU_{x,y} &gt; 510</math>, then <math>Pixel_{x,y} = (Pixel_{x+1,y} + Pixel_{x-1,y}) / 2</math> ' replace</p>

<b>Name</b>	<b>flatfieldCorrectionPixelReplacementAlgorithm</b>
Display Name	<b>Pixel Replacement Algorithm</b>
Name Space	DFNC
Firmware Release	05
Visibility	Expert
Access	Read-Only
Type	Enumeration
Values	<p>Method1(Average/ Copy Adjacent) – the algorithm consists of averaging the adjacent pixels when replacing a single defect and copying the nearest pixel when replacing two consecutive defects or a defect at the beginning or end of a line, i.e.  A= pixel A  B= pixel B  X= defect</p> <p>AXB is corrected to ACB where:  <math>C = (A+B) / 2</math>  AXXB is corrected to AABB  XA is corrected to AA  BX is corrected to BB</p> <p>Method3(Average/ Weighted Average) is a custom enumeration. algorithm consists of averaging the adjacent pixels when replacing a single defect and performing a weighted average when replacing two consecutive defects. A defect at the beginning or end of a line is not corrected, i.e.  A= pixel A  B= pixel B  X= defect</p> <p>AXB is corrected to ACB where:  <math>C = (A+B) / 2</math>  AXXB is corrected to ACDB where  <math>C = (11 * A + 5 * B) / 16</math>  <math>D = (5 * A + 11 * B) / 16</math></p> <p>XA is not corrected  BX is not corrected</p>
Notes	Selects the pixel replacement algorithm.
<b>Name</b>	<b>flatfieldCalibrationPixelReplacement</b>
Display Name	<b>Pixel Replacement Calibration</b>
Name Space	Custom
Firmware Release	05
Visibility	Guru
Access	Read-Write when flatfieldCorrectionMode = "Calibration"
Type	Command
Notes	<p>Performs pixel defects calibration. This is a cumulative function (i.e. defects are added to the current defect map).  For each pixel:  If <math>ABS(AveragedDarkValue_{x,y} - FPN_{x,y}) &gt; flatfieldCalibrationPixelReplacementOffsetThreshold</math>  then <math>FPN_{x,y} = 127</math> ' mark as bad</p>
<b>Name</b>	<b>flatfieldCalibrationPixelReplacementOffsetThreshold</b>
Display Name	<b>Pixel Replacement Calibration Threshold</b>
Name Space	Custom
Firmware Release	05
Visibility	Guru
Access	Read-Write when flatfieldCorrectionMode = <i>Calibration</i>
Type	Integer
Values	1 to 127
Notes	Specifies the offset (FPN) value above which the pixel is marked as defective.

<b>Name</b>	<b>flatfieldCalibrationPixelReplacementGainThreshold</b>
Display Name	<b>Pixel Replacement Calibration Threshold</b>
Name Space	Custom
Firmware Release	05
Visibility	Guru
Access	Read-Write when flatfieldCorrectionMode = "Calibration"
Type	Float
Values	1.5 to 9 (when <i>flatfieldCalibrationGainMode</i> = High Resolution) 2 to 17 (when <i>flatfieldCalibrationGainMode</i> = High Gain)
Notes	Specifies the gain (PRNU) value, above which the pixel is marked as defective. Only used in calibration.
<b>Name</b>	<b>flatfieldCalibrationHotPixelsReplaced</b>
Display Name	<b>Hot Pixels Replaced</b>
Name Space	Custom
Firmware Release	05
Visibility	Guru
Access	Read-Only
Type	Integer
Values	0 to ( <i>Width * Height</i> )
Notes	Displays the number of hot pixels (i.e. with uncorrectable FPN) that have been replaced.  Use <b>flatfieldCalculatePixelStatistics</b> to calculate this value.
<b>Name</b>	<b>flatfieldCalibrationUncorrectableHotPixels</b>
Display Name	<b>Uncorrectable Hot Pixels</b>
Name Space	Custom
Firmware Release	06
Visibility	Guru
Access	Read
Type	Integer
Values	0 to ( <i>Width * Height</i> )
Notes	Reports the number of hot pixels (i.e. with uncorrectable FPN) that can not be replaced. The camera cannot correct any more than two horizontally adjacent pixels (i.e. only the pixels on the ends of a horizontal cluster will get corrected).  Note: Hot Pixels and dead pixels will interact. For example, if there are 2 hot pixels in a row, followed by a dead pixel, then the middle hot pixel will be uncorrectable.  Use <b>flatfieldCalculatePixelStatistics</b> to calculate this value.
<b>Name</b>	<b>flatfieldCalibrationDeadPixelsReplaced</b>
Display Name	<b>Dead Pixels Replaced</b>
Name Space	Custom
Firmware Release	05
Visibility	Guru
Access	Read
Type	Integer
Values	0 to ( <i>Width * Height</i> )
Notes	Displays the number of dead pixels (i.e. with uncorrectable PRNU) that have been replaced.  Use <b>flatfieldCalculatePixelStatistics</b> to calculate this value.

<b>Name</b>	<b>flatfieldCalibrationUncorrectableDeadPixels</b>
Display Name	<b>Uncorrectable Dead Pixels</b>
Name Space	Custom
Firmware Release	06
Visibility	Guru
Access	Read
Type	Integer
Values	0 to (Width * Height)
Notes	<p>Reports the number of dead pixels(i.e. with uncorrectable PRNU) that can not be replaced. The camera cannot correct any more than two horizontally adjacent pixels(i.e. only the pixels on the ends of a horizontal cluster will get corrected) .</p> <p>Note: Hot Pixels and dead pixel will interact. For example if there are 2 hot dead in a row, followed by a hot pixel, then the middle dead pixel will be uncorrectable.</p> <p>Use <b>flatfieldCalculatePixelStatistics</b> to calculate this value.</p>
<b>Name</b>	<b>flatfieldCalibrationOffsetPixelsClipped</b>
Display Name	<b>Offset Pixels Clipped</b>
Name Space	Custom
Firmware Release	05
Visibility	Guru
Access	Read-Only
Type	Integer
Values	0 to (Width * Height)
Notes	Displays the number of pixels that have an FPN coefficient of 0. This can be result of setting the black offset value too high.
<b>Name</b>	<b>flatfieldCalibrationDeadPixelsNotReplaced</b>
Display Name	<b>Dead Pixels NOT Replaced</b>
Name Space	Custom
Firmware Release	05
Visibility	Guru
Access	Read-Only
Type	Integer
Values	0 to (Width * Height)
Notes	Displays the number of dead pixels (i.e. with uncorrectable PRNU) that have been set to the maximum gain but not replaced. This would include any pixel value that exceeds the maximum gain (i.e. either 1.5 or 2, depending on <i>flatfieldCalibrationGainMode</i> ) but less than <i>flatfieldCalibrationPixelReplacementGainThreshold</i> .
<b>Name</b>	<b>flatfieldCalibrationGainPixelsClipped</b>
Display Name	<b>Gain Clipped Pixels</b>
Name Space	Custom
Firmware Release	05
Visibility	Guru
Access	Read-Only
Type	Integer
Values	0 to (Width * Height)
Notes	Specifies the number of pixels that have a correction factor of less than 1. If this number is too high, it means that the Gain target is set too low.
<b>Name</b>	<b>flatfieldCalculatePixelStatistics</b>
Display Name	<b>Calculate Pixel Statistics</b>
Name Space	Custom
Firmware Release	06
Visibility	Guru
Access	Read-Write
Type	Command
Values	
Notes	This command calculates the pixel statistics.

<b>Name</b>	<b>defectivePixelDetectionAlgorithmSelector</b>
Display Name	<b>Dynamic Replacement Algorithm</b>
Name Space	Custom
Firmware Release	05
Visibility	Expert
Access	Read-Write
Type	Enumeration
Values	<i>Method3</i> (Pre-Correction Median Filter) - Horizontal Median Filter. Before FFC Correction. <i>Method4</i> (Post-Correction Median Filter) - Horizontal Median Filter. After FFC Correction.
Notes	Enables or disables dynamic defective pixel detection and replacement. Note that each filter can be active at the same time.
<b>Name</b>	<b>defectivePixelDetectionMode</b>
Display Name	<b>Dynamic Replacement Mode</b>
Name Space	DFNC
Firmware Release	05
Visibility	Expert
Access	Read-Write
Type	Enumeration
Values	<i>Active</i> - Enable dynamic defective pixel replacement. <i>Off</i> - Disable dynamic defective pixel replacement.
Notes	Enables or disables the dynamic defective pixel detection and replacement for the selected algorithm.  If $(ABS(Pixel_{x,y} - Pixel_{x-1,y}) > defectivePixelDetectionMinBrightThreshold \text{ AND } ABS(Pixel_{x,y} - Pixel_{x+1,y}) > defectivePixelDetectionMinBrightThreshold)$ THEN $Pixel_{x,y} = \text{Median}(Pixel_{x-1,y}, Pixel_{x,y}, Pixel_{x+1,y})$  Note: both the Pre and Post filters can be active at the same time.
<b>Name</b>	<b>defectivePixelDetectionMinBrightThreshold</b>
Display Name	<b>Dynamic Replacement Min Threshold</b>
Name Space	DFNC
Firmware Release	05
Visibility	Guru
Access	Read-Write
Type	Integer
Values	1 to 255
Notes	Defines the maximum threshold value that a pixel can achieve before being corrected.
<b>Name</b>	<b>simpleFeedThroughCoeff1, simpleFeedThroughCoeff2, simpleFeedThroughCoeff3</b>
Display Name	<b>Simple Feedthrough Correction Coeff 1 - Coeff 3</b>
Name Space	Custom
Firmware Release	00
Visibility	Guru
Access	Read-Write
Type	Integer
Values	-127 to 127
Notes	Retrieves and sets the simple feed through correction coefficient.
<b>Name</b>	<b>feedThroughCorrectionMode</b>
Display Name	<b>Feed Through Correction Apply</b>
Firmware Release	00
Name Space	Custom
Visibility	Guru
Access	Read-Write
Type	Enumeration
Values	<i>Off</i> - Disable feedthrough correction <i>On</i> - Enable feedthrough correction
Notes	Apply the feed through correction.

## Invisible Features

<b>Name</b>	<b>flatfieldAlgorithmBufferFormat</b>
Name Space	DFNC
Firmware Release	05
Visibility	Invisible
Access	Read Only
Type	Enumeration
Values	<i>Mono8</i>
Notes	Each flat field coefficient is stored as an 8 bit number. This feature is used for Sopera FFC support.
<b>Name</b>	<b>flatfieldAlgorithmBufferWidth</b>
Name Space	DFNC
Firmware Release	05
Visibility	Invisible
Access	Read Only
Type	Integer
Values	<i>SensorWidth</i>
Notes	The width of the flat field correction buffer in pixels. Used for Sopera FFC Support.
<b>Name</b>	<b>flatfieldAlgorithmBufferHeight</b>
Name Space	DFNC
Firmware Release	05
Visibility	Invisible
Access	Read Only
Type	Integer
Values	<i>SensorHeight</i>
Notes	The height of the flat field correction buffer in pixels. Used for Sopera FFC Support.
<b>Name</b>	<b>flatfieldAlgorithmGainDivisor</b>
Name Space	DFNC
Firmware Release	05
Visibility	Invisible
Access	Read Only
Type	Integer
Values	512
Notes	The camera uses this value to calculate the FFC gain factor. Used for Sopera FFC Support. This is equivalent to the high gain setting with the in-camera calibration. In other words when you calibrate the camera in the host, it can only be a High Gain PRNU calibration. See formula.
<b>Name</b>	<b>flatfieldAlgorithmGainBase</b>
Name Space	DFNC
Firmware Release	05
Visibility	Invisible
Access	Read Only
Type	Integer
Values	1
Notes	The off camera uses this value to calculate the FFC gain factor. Used for Sopera FFC Support. See formula.
<b>Name</b>	<b>flatfieldAlgorithmOffsetMax</b>
Name Space	DFNC
Firmware Release	05
Visibility	Invisible
Access	Read Only
Type	Integer
Values	126
Notes	The maximum valid offset coefficient value. Used for Sopera FFC Support.

<b>Name</b>	<b>flatfieldAlgorithmOffsetMin</b>
Name Space	DFNC
Firmware Release	05
Visibility	Invisible
Access	Read Only
Type	Integer
Values	1
Notes	The minimum valid offset coefficient value. Used for Sopera FFC Support.
<b>Name</b>	<b>flatfieldAlgorithmOffsetFactor</b>
Name Space	DFNC
Firmware Release	05
Visibility	Invisible
Access	Read Only
Type	Integer
Values	1.0
Notes	The multiplier applied to the FFC offset values. Used for Sopera FFC Support. See formula
<b>Name</b>	<b>flatfieldAlgorithmGainMax</b>
Name Space	DFNC
Firmware Release	05
Visibility	Invisible
Access	Read Only
Type	Integer
Values	510
Notes	The maximum valid gain coefficient value. Used for Sopera FFC Support.
<b>Name</b>	<b>flatfieldAlgorithmGainMin</b>
Name Space	DFNC
Firmware Release	05
Visibility	Invisible
Access	Read Only
Type	Integer
Values	0
Notes	The minimum valid gain coefficient value. Used for Sopera FFC Support.
<b>Name</b>	<b>complexFeedThroughCoeff1, complexFeedThroughCoeff2, complexFeedThroughCoeff3</b>
Display Name	<b>Complex Feedthrough Correction Coeff 1 - Coeff 3</b>
Firmware Release	00
Name Space	Custom
Visibility	Invisible
Access	Read-Write
Type	Integer
Values	-127 to 127
Notes	Gets and sets the simple feed through correction coefficient. For internal use.

## Flat Field Correction and Defective Pixel Detection Overview

The Flat Field correction function consists of using two coefficients per pixel which correct the gain and offset of the corresponding pixel. These corrections compensate for the Photo-response Non-uniformity (PRNU) and Fixed Pattern noise (FPN) attributes unique to each camera sensor. In addition, the camera supports replacement of defective pixels (hot, dead, blinking) with a value based on neighbourhood pixels.

### Correction Function Block Diagram

The following simplified block diagram shows the processing chain that is applied to the image data (the flat field and defective pixel blocks are highlighted). Note that each processing block can be activated and deactivated independently. For example, the FPN and PRNU coefficients can be applied independently or together using the *flatfieldCorrectionMode*.

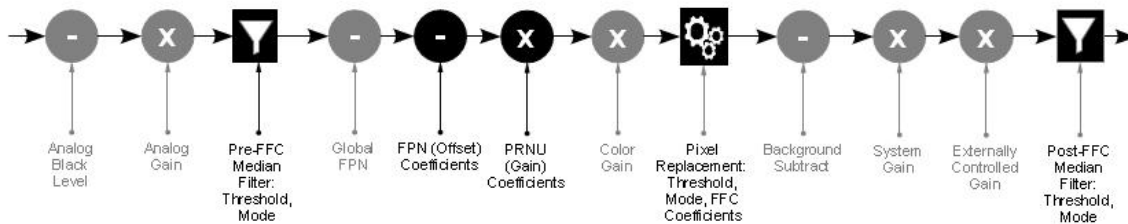


Figure 22 Flat field and defective pixel processing

### Flat Field Correction Algorithm Description

Flat Field Correction Algorithm–Method1 (feature: *flatfieldCorrectionAlgorithm*) applies the following FFC formula for correcting pixel values:

$$\text{newPixelValue}_{x,y} = (\text{sensorPixelValue}_{x,y} - \text{FFCOffset}_{x,y}) * \text{FFCGain}_{x,y}$$

where:

- **x & y** are the Flat Field Correction Pixel coordinates. See the *flatfieldCorrectionPixelXCoordinate* and *flatfieldCorrectionPixelYCoordinate* features.
- **newPixelValue** is the pixel value after Flat Field Correction is applied.
- **sensorPixelValue** is the pixel value before Flat Field correction is applied.
- **FFCOffset** is the offset coefficient value to subtract from the sensorPixelValue.
- **FFCGain** is the gain coefficient value that is multiplied with the sensorPixelValue.

The implementation of this formula requires that both the FPN and PRNU coefficient are stored in 16 bits. For the Falcon2 we reserve 7 bits for the FFCOffset (FPN) coefficient and 9 bits for the FFCGain (PRNU) coefficient. The FFCGain can be calculated as follows:

$$\text{FFCGain}_{x,y} = (\text{FFCGainRaw}_{x,y} / \text{GainDivisor}) + 1.0$$

where:

- **x & y** are the Flat Field Correction Pixel coordinates.
- **FFCGain** is the floating point multiplier of the sensorPixelValue.
- **FFCGainRaw** is the stored 9 bit value representing the FFC gain value.
- **GainDivisor** is either 512 or 1024 depending on whether the camera was calibrated in High resolution or high gain mode. See *flatfieldCalibrationGainMode* and *flatfieldCorrectionGainMode*.



## General Notes on FFC calibration

The camera comes calibrated with three factory sets, one for each sensor bit depth. These sets switch automatically when the user changes *pixelSizeInput*. In addition to the factory calibrations, the camera provides four user configurable FFC sets. These can be calibrated and saved in the camera. For more information on this, see “How to do an FFC Setup in the Camera”.

Another option is to perform the flat field correction in the frame grabber. See the section How to do a FFC Setup via Sapera CamExpert for more information.

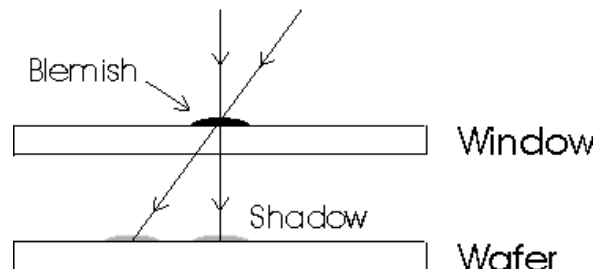
In either case, we recommend that you repeat the correction when a temperature change of greater than 10 °C occurs.

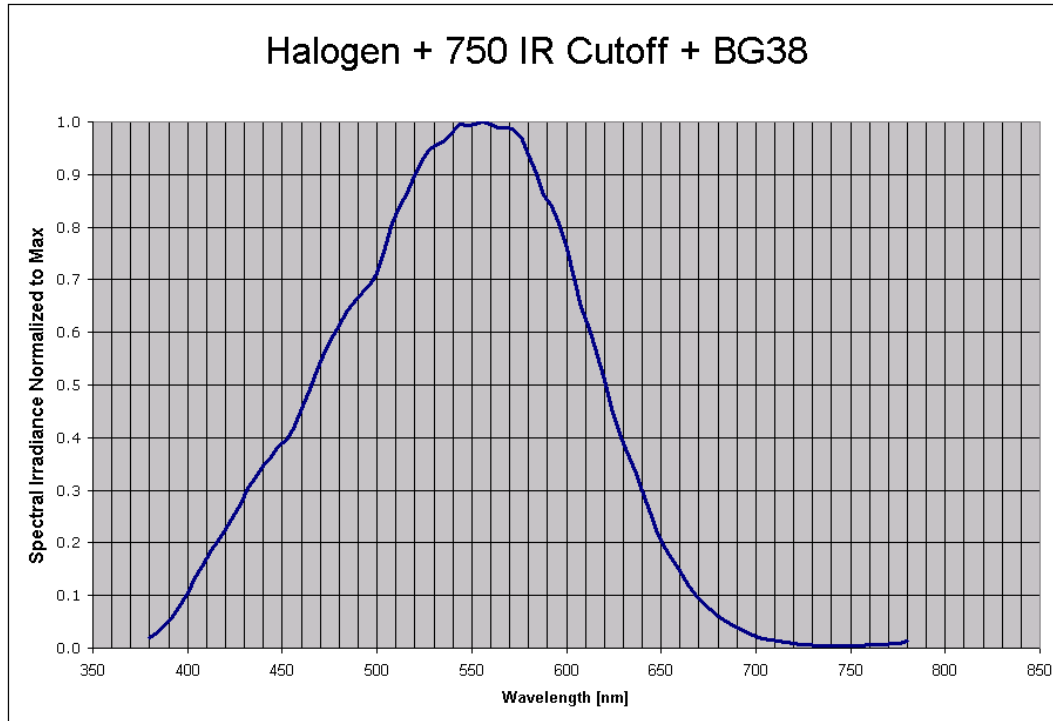
### For best results, ensure that:

1. Gain (PRNU) calibration has a clean, white reference. The quality of this reference is important for proper calibration. White paper is often not sufficient because the grain in the white paper will distort the correction. White plastic or white ceramic will lead to better balancing.
2. Ambient light flicker (e.g. fluorescent lights) is sufficiently low not to affect camera performance and calibration results.
3. The average pixel should be at least 20 % below the target output. If the target is too close, then some pixels may not be able to reach full swing due to correction applied by the camera.
4. When 6.25 % of pixels from a single row within the region of interest are clipped, flat field correction results may be inaccurate.
5. Correction results are valid only for the current black offset values. If you change this value, it is recommended that you recalculate your coefficients.

### An important note on window blemishes:

When flat field correction is performed, window cleanliness is paramount. The figure below shows an example of what can happen if a blemish is present on the sensor window when flat field correction is performed. The blemish will cast a shadow on the wafer. FFC will compensate for this shadow by increasing the gain. Essentially FFC will create a white spot to compensate for the dark spot (shadow). As long as the angle of the incident light remains unchanged then FFC works well. However when the angle of incidence changes significantly (i.e. when a lens is added) then the shadow will shift and FFC will make things worse by not correcting the new shadow (dark spot) and overcorrecting where the shadow used to be (white spot). While the dark spot can be potentially cleaned, the white spot is an FFC artefact that can only be corrected by another FFC calibration.





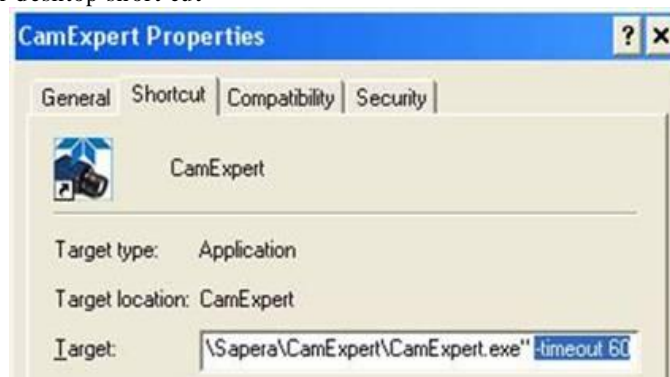
**Figure 23. Spectral distribution of light source used during calibration of color cameras only. This corresponds roughly to a 5200 K color temperature.**

## How to do an FFC Setup in the Camera



CamExpert has a default timeout of 20 seconds per command, which is too short for the FFC calibration to run fully. You can change the default timeout by setting a command line argument in the short-cut:

- Right click on the short-cut in the start menu and select properties.
- Add `-timeout 60` to increase the command timeout to 60 seconds (See below)
- Repeat for desktop short-cut



**Figure 24: Setting the camera's timeout value**

The calibration is performed in two steps. The fixed offset (FPN) is determined first by performing an averaging without any light. This calibration determines exactly how much offset to subtract per pixel in order to obtain flat output when the sensor is not exposed.

If the camera is run at exposure time that is significantly higher than the calibration exposure, an additional Pixel Replacement Calibration may be required.

The gain (PRNU) calibration is performed next to determine the multiplication factors required to bring each pixel to the required value (target) for flat, white output. For the monochrome cameras, the target is determined by the user (See *flatfieldCalibrationTarget*). The color camera requires a separate target for each color which is calculated as 23 % higher than the average pixel for the given color.

It is important to do the FPN correction first. Results of the FPN correction are used in the PRNU procedure.

**Let's go through a flat field calibration example:**

1. The camera is placed in **internal exposure and frame rate**. Make sure that the area of interest (AOI) is set to the full window (i.e. Width=SensorWidth and Height=SensorHeight). No other exposure mode or AOI configuration will allow FFC calibration. See *ExposureMode*, *TriggerMode*, *OffsetX*, *OffsetY*, *Width*, *Height*.
2. Settings such as frame rate, exposure time, etc. are set as close as possible to the actual operating conditions. Set **system gain to 1** and **background subtract to 0**, as these are the defaults during FFC calibration. See *GainSelector*, *Gain*, *BlackLevelSelector*, and *BlackLevel*.
3. Select **correction active set to user flat field 1**. Go to **flat field correction mode**, select **calibration**. See *flatfieldCorrectionCurrentActiveSet*, and *flatfieldCorrectionMode*.
4. Clear existing coefficients. See *flatfieldCalibrationClearCoefficient*.
5. Place the camera in the dark (i.e. cover lens) and run **FPN calibration**. This performs the FPN correction and saves the FPN coefficients to temporary memory. See *flatfieldCalibrationFPN*.
6. Calibration mode enables both FPN and PRNU correction. Verify signal output is close to 0 DN.
7. Illuminate the sensor to 65 % saturation, using a high quality white reference.
8. Set **flat field target** to 80 % saturation (monochrome only). See *flatfieldCalibrationTarget*.
9. Select Gain Calibration Mode as either High Gain or High Resolution
10. Run **Gain (PRNU) calibration**. See *flatfieldCalibrationPRNU*.
11. [Optional] Set the **exposure time** to {X % longer than} the longest value that will be required by the user's system. Set the **pixel replacement calibration threshold** to 60. Run **pixel replacement calibration**. See "*Hot Pixels and Long Exposure Times*" for more information about why this is necessary. See *ExposureTime*, *flatfieldCalibrationPixelReplacementThreshold* and, *flatfieldCalibrationPixelReplacement*
12. **Save** the flat field calibration: *flatfieldCalibrationSave*.

**Here is the factory calibration procedure for the 8M camera:**

1. The camera is placed in full internal, 8 taps, 10 bits, active window (3328 x 2816, only available to factory), system gain 1, color gain 1, background subtract 0, global FPN calibrated such that dark FPN is 30 DN (10 bit) 50 fps, 1500  $\mu$ s exposure. For color, use 20 fps, 25000  $\mu$ s exposure. This last part is important (mono: 50 fps, 1500  $\mu$ s exposure. Color: 20fps 25000  $\mu$ s exposure) and ensures that the camera is in non-concurrent mode. In non-concurrent mode, readout and integration do not overlap thus eliminating some residual artefacts.
2. The camera is placed in the dark and **FPN Calibration** is run.
3. With FPN correction on the sensor is illuminated (Light Source: Broadband Quartz Halogen, 3250 K, with a 750 nm cut-off filter) with a light level of 26.4  $\mu$ W/ cm<sup>2</sup> (10 BPP). This ensures each

camera will have the same responsivity since the light level and target value are always the same. Typical output levels for the camera at this light level are 680 DN (10 bit).

4. The sensor window at this point has been cleaned thoroughly such that there are no significant blemishes present.
5. For the monochrome camera only, PRNU target is set to 840 DN (82.11 % peak).
6. PRNU calibration is run.

### How can one match gain and offset values on multiple cameras?

One way is of course to use flat field correction. All cameras would be set up under the same conditions, including lighting, and then calibrated with FPN and PRNU. This process can be time-consuming and complicated (especially the white target). Another way is to use global FPN (Sensor Control > Black Level Selector > DigitalAll1):

1. Starting from factory settings (factory flat field), take note what the highest dark offset is among the set of cameras. If the highest dark offset is higher than about 16 DN (10 bit) you might want to consider recalibrating the FPN correction. You can use the histogram feature in CamExpert to determine this value see Figure 25. Large differences in dark offset between the factory and user are typically caused by differences in temperature from factory to user. Large dark offsets will result in PRNU-correction-induced FPN and should therefore be avoided.
2. Decrease global FPN (increase the offset in dark) on all cameras until they are the same and reach at least 4 DN (10 bit).
3. Illuminate to about 80 % saturation (820 DN, 10 bit) and note the highest signal level among the set of cameras.
4. Increase the system gain (Sensor Control > Gain Selector > DigitalAll1) on the cameras until they all reach the same output level (highest of all cameras).
5. Place camera in the dark and repeat step 2 to 4 until both dark offset and 80 % sat signal levels are equal on all cameras.

### Hot Pixels and Long Exposure Times

The camera is calibrated and optimized for an exposure time of 1500 microseconds providing peak FPN and PRNU performance are at this setting. This FPN correction also manages hot pixels for the same exposure time. Changing the exposure time to very long times, such as 60000 microseconds, can introduce additional uncorrected hot pixels in the image. The user can eliminate these pixels by performing a user pixel replacement calibration which will capture and correct these pixels. This correction eliminates hot pixels at long exposure time while maintaining the same FPN characteristics.

## How to do a FFC Setup via Sapera CamExpert

The Sapera LT CamExpert tool provides an easy GUI based method for a user to perform a Flat Field Calibration. The process first requires the user to plan acquisitions in dark and bright conditions, followed by the FFC process itself. Please review the list of best practices in the *General Notes on FFC calibration* section. The steps to perform a FFC calibration using CamExpert are detailed below.

1. Verify a Dark Acquisition.

Close the camera lens iris and cover the lens with a lens cap. Using CamExpert, click on the grab button and then the histogram button. The following figure shows a typical histogram for a Falcon2 grabbing a very dark image.

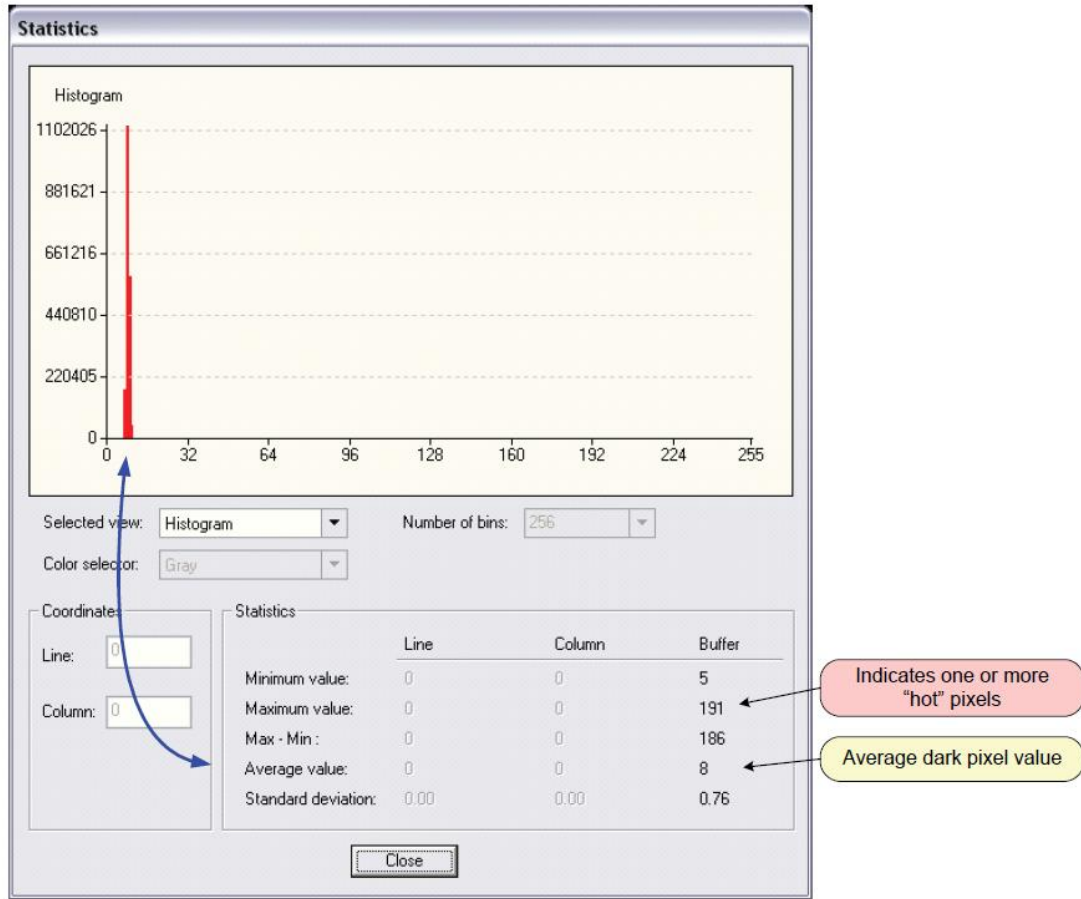


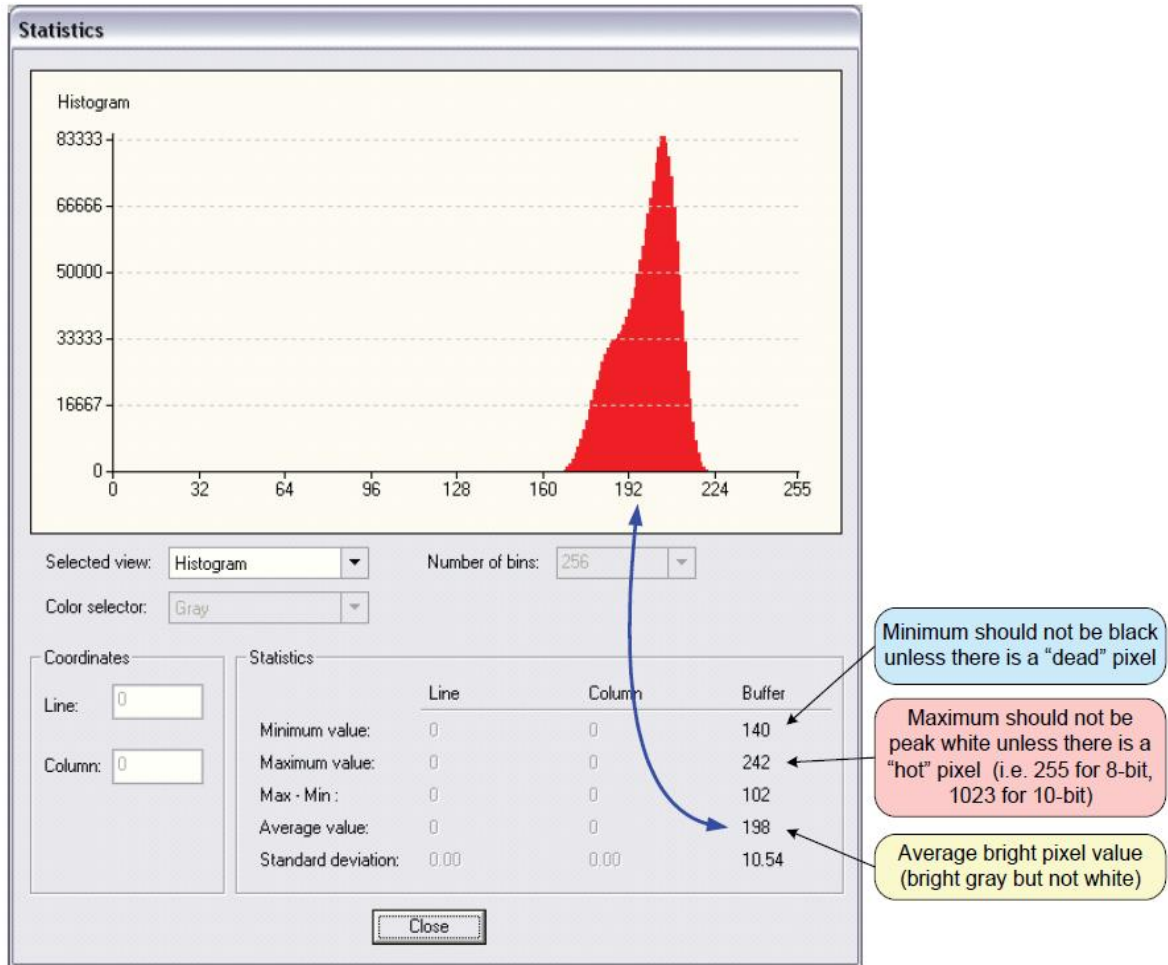
Figure 25 CamExpert histogram of a dark scan (8 bit output)



**Important:** In this example, the **average** pixel value for the frame is close to black. Also note that most sensors will show a much higher maximum pixel value due to one or more "hot pixels". The sensor specification accounts for a small number of hot or stuck pixels (pixels that do not react to light over the full dynamic range specified for that sensor).

## 2. Verify Bright Image

Aim the camera at the PRNU reference. Using CamExpert, click on the grab button and then the histogram button. Use the lens iris to adjust for a bright gray approximately around a pixel value of 200 (for 8-bit pixels). The following figure shows a typical histogram for a Falcon2 grabbing a bright gray image.



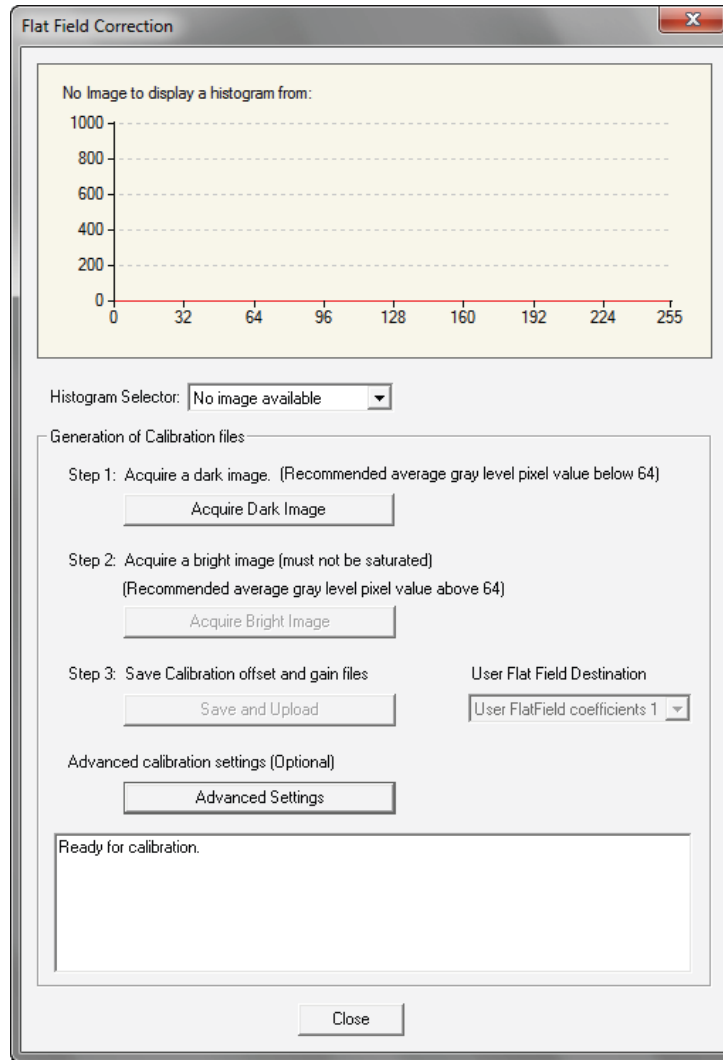
**Important:** In this example, the **average** pixel value for the frame is bright gray. Also note that sensors may show a much higher maximum or a much lower minimum pixel value due to one or more "hot or dead pixels". The sensor specification accounts for a small number of hot, stuck, or dead pixels (pixels that do not react to light over the full dynamic range specified for that sensor).

Once the bright gray acquisition setup is done, note the camera position and lens iris position so as to be able to repeat it during the calibration procedure.

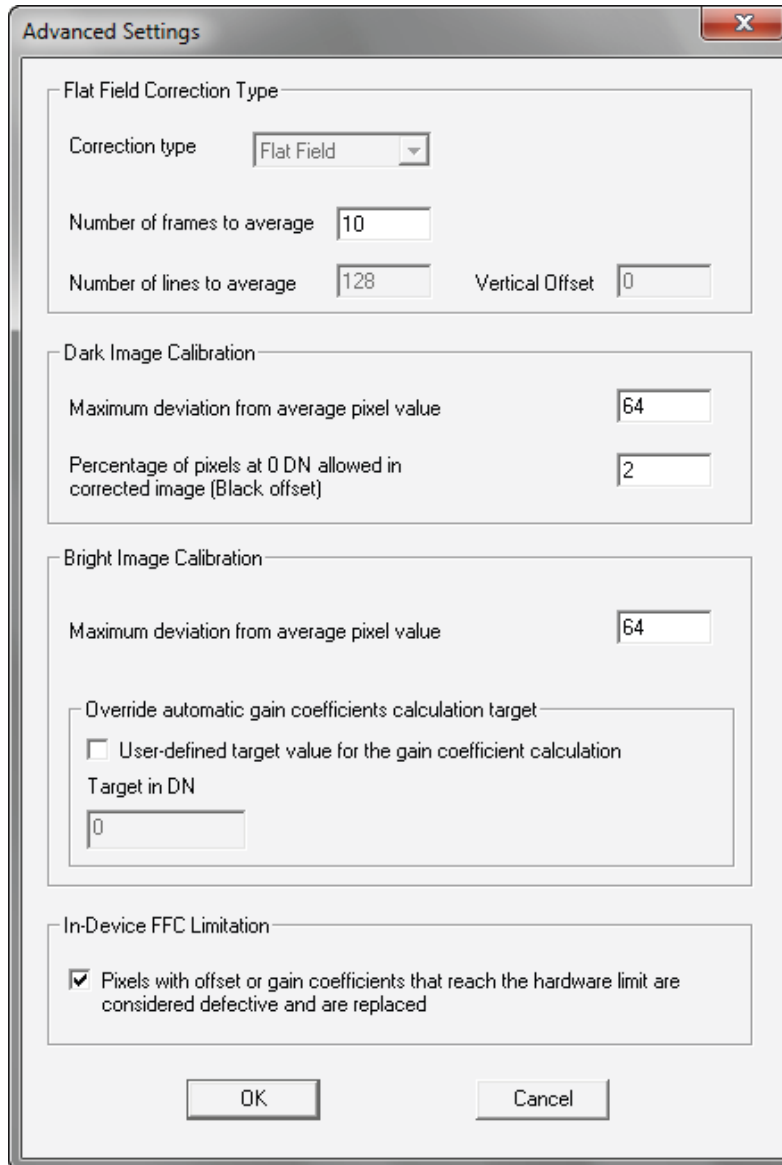
3. Start the Flat Field calibration tool via the CamExpert menu bar:

Pre-processing > Flat Field Correction > Calibration.

The Flat Field calibration window provides a three step process to acquire two reference images and then save the flat field correction data for the camera used. To aid in determining if the reference images are valid, a histogram tool is provided so that the user can review the images used for the correction data. Note that it is important to follow the instructions in the preceding section to prepare for the dark and light acquisition steps required for calibration.



4. Click on the **Advanced Setting** button to change the default number of frames averaged for each calibration step. The default value is 10 frames (as performed by CamExpert).



5. Setup the camera to capture a uniform dark image. Black paper with no illumination and the camera lens' iris closed to minimum can provide such a dark image. Or cover the lens with a black lens cap.
6. Click on **Acquire Black Image**. The flat field calibration tool will grab video frames, analyze the pixel gray level spread, and present the statistics. The desired black reference image should have pixel values less than 20. If the results are acceptable, accept the image as the black reference.
7. Setup the camera to acquire a uniform white image (but not saturated white). Even illumination on white paper can be used, with a gray level of minimum of 128 (8-bit mode). It is preferable to prepare for the white level calibration step before starting the calibration procedure (see the previous section for information).
8. Click on **Acquire White Image**. The flat field demo will grab video frames, analyze the pixel gray level spread, and present the statistics. The captured gray level for all pixels should be greater than 128 but not saturated. If the histogram shows a good grab accept the image as the white reference.



9. Click on **Save**. The flat field correction data is saved as a TIF image with a file name of your choice (suggestions are the camera name and its serial number).

### Using Flat Field Correction

When using CamExpert, from the menu bar enable Flat Field correction (Pre-Processing • Flat Field Correction • Hardware). Now when doing a live grab or snap, the incoming image is corrected by the current flat field calibration data for each pixel. Use the CamExpert menu function Tools • Flat Field Correction • Load to load in a flat field correction image from previously saved calibration data. CamExpert allows saving and loading calibration data for all cameras used with the imaging system.

### Uploading Coefficient to the Camera

Flat field coefficients can be uploaded to the camera via the file access control features. The Flat Field Coefficients File is a standard TIF file. A Spera application (such as CamExpert) creates a new SapBuffer object of the same width as the image buffer but with twice the number of lines. This provides the room to store both offset and gain Flat Field data. The Flat Field offset data is contained in the top half of the new buffer, while the gain buffer is in the bottom half.

A Spera application saves the new buffer using SapBuffer::Save with the "-format tiff" option, which allows saving data without loss of significant bits.

## Defective Pixel Detection and Replacement

The camera has two methods of replacing pixels. Static pixel replacement uses the FFC coefficients to mark pixels that will be replaced. Dynamic pixel replacement consists of a median filter that is applied when the given pixel is above a threshold when compared to adjacent pixels.

### Static Pixel Replacement

This is a technique for the elimination of dead or hot pixels. A pixel on the left edge (beginning of the line) would be replaced with the pixel to its right, while a pixel on the right edge (end of the line) is replaced with the pixel to its left. Any pixel within a line is replaced with the average of its neighboring pixels (on the same line). For color sensors, the same algorithm is used except the replacement pixel is of the same color. Note that three horizontally adjacent defective pixels cannot be replaced.

The camera uses the FFC coefficients to indicate which pixels need to be replaced. If a pixel has a Gain (PRNU) coefficient that is equal to the maximum gain (i.e. approx 1.5 for High resolution and 2 for High Gain mode) then the pixel will be marked for replacement. Additionally, a pixel will be replaced if it has an Offset (FPN) coefficient that is greater than the pixel replacement threshold (*flatfieldCorrectionPixelReplacementThreshold*). Lowering this threshold will remove more pixels with high offset coefficients.

Most hot and dead pixels will be identified when a FPN or PRNU calibration is performed in camera. The user can also manually mark a pixel for replacement by setting its Offset Coefficient to 127. After the flat field calibration has been performed, the user can increase the exposure time, cover the sensor, and run a pixel replacement calibration (*flatfieldCalibrationPixelReplacement*). See the section entitled **Hot Pixels and Long Exposure Times** for more information on why this needs to be done.

The pixel replacement calibration algorithm adds the new found hot pixels to the pixel defect map and must be run after an offset calibration. If the difference between the average pixel value and the stored offset value (FPN coefficient) is greater than the calibration threshold (i.e. *flatfieldCalibrationPixelReplacementOffsetThreshold*) then the pixel is marked for replacement. Typically, the pixel replacement calibration should be run at the highest exposure time used in the target system. See Appendix D: Internal Flat Field Calibration Algorithms for more information on the algorithm.

## Dynamic Pixel Replacement

Dynamic pixel replacement does not require calibration. It compares a given pixel with its horizontally adjacent neighbors. If the difference between the pixel and each neighbor is greater than the defined threshold (*defectivePixelDetectionMinBrightThreshold*) then the pixel is replaced by the median of the three pixels.

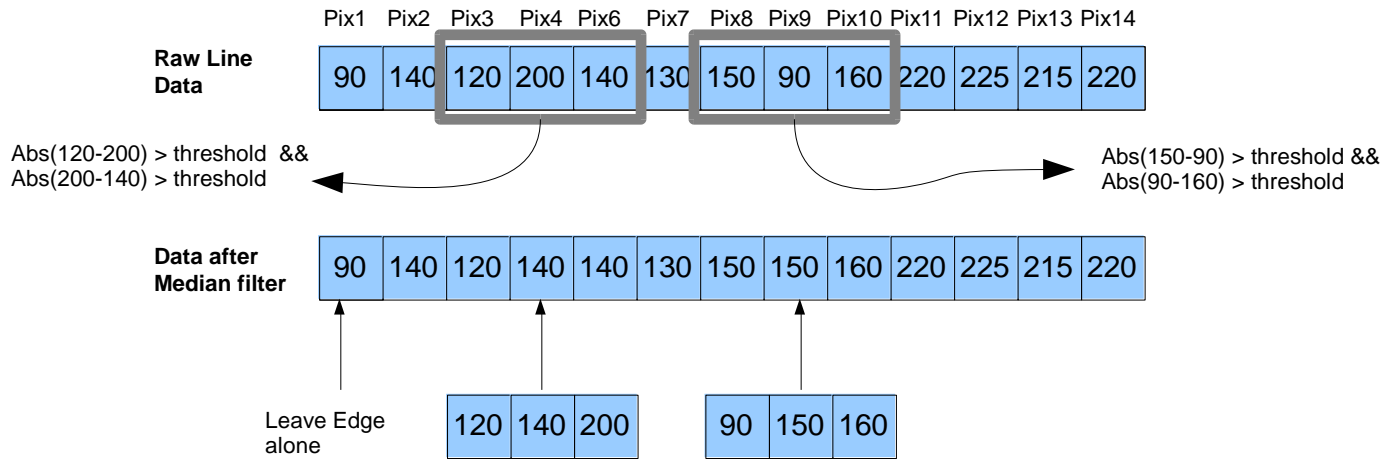


Figure 26 Monochrome Median Filter

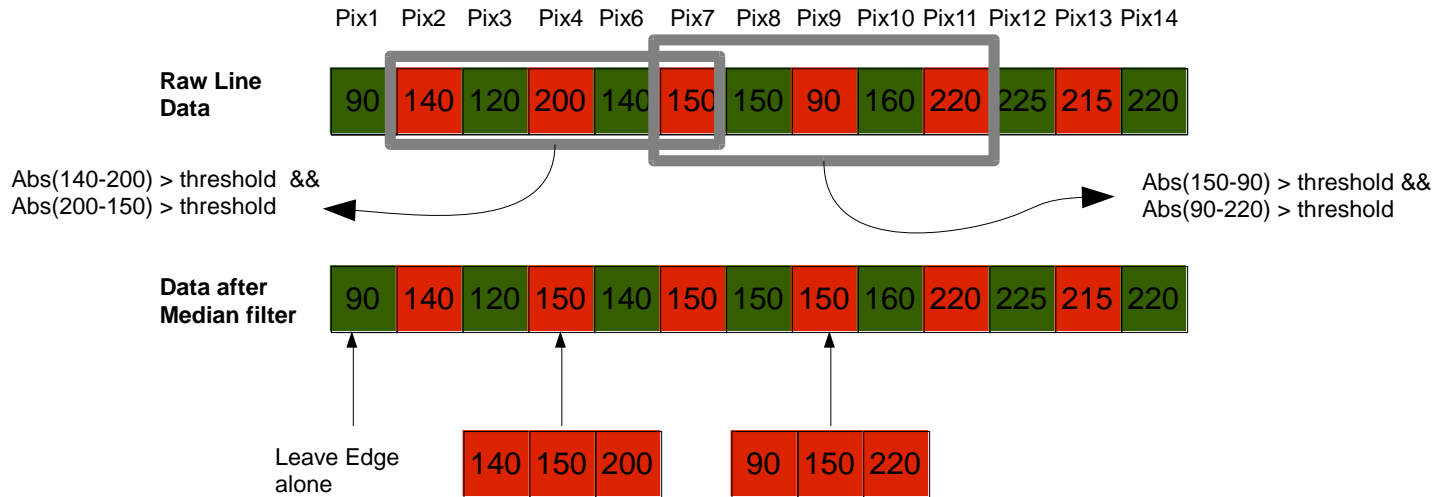


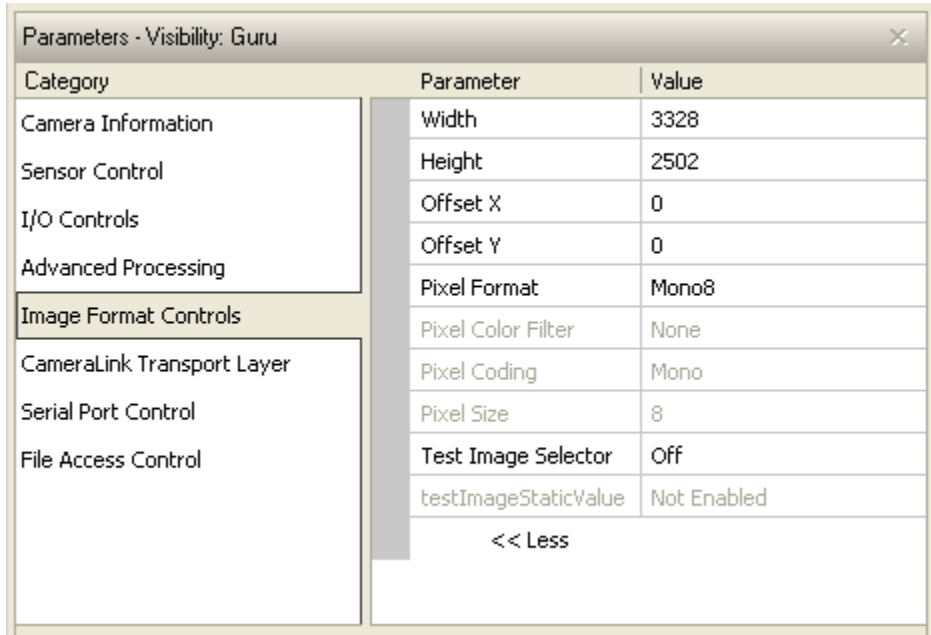
Figure 27 Color Median Filter

## Image Format Controls Category

The camera Image Format controls, as shown by CamExpert, groups parameters used to configure camera pixel format, and image cropping, Additionally, a feature control to select and output an internal test image simplifies qualifying a camera setup without a lens.

Parameters in gray are read only, either always or due to another parameter being disabled. Parameters in black are user set in CamExpert or programmable via an imaging application.

Features listed in the description table but tagged as *Invisible* are usually for Teledyne DALSA Support or third party software usage—not typically required by end user applications.



**Figure 28 Image Format Controls as shown in CamExpert**

The following table describes these parameters along with their view attribute and minimum camera firmware version required. Additionally the table will indicate which parameter is a member of the DALSA Features Naming Convention (DFNC), GenICam Standard Features Naming Convention or custom camera feature.

Name	Width
Display Name	<b>Width</b>
Name Space	SFNC
Firmware Release	00
Visibility	Beginner
Access	Read-Write
Type	Integer
Values	<b>Minimum:</b> 512 <b>Maximum:</b> <i>SensorWidth - OffsetX</i> <b>Increment:</b> 128
Name	Height
Display Name	<b>Height</b>
Name Space	SFNC
Firmware Release	00
Visibility	Beginner
Access	Read-Write
Type	Integer
Values	<b>Minimum:</b> 2 <b>Maximum:</b> <i>SensorHeight - OffsetY</i> <b>Increment:</b> 2

<b>Name</b>	<b>OffsetX</b>
Display Name	<b>Offset X</b>
Name Space	SFNC
Firmware Release	00
Visibility	Beginner
Access	Read-Write
Type	Integer
Values	<b>Minimum:</b> 0 <b>Maximum:</b> <i>SensorWidth – Width</i> <b>Increment:</b> 128
<b>Name</b>	<b>OffsetY</b>
Display Name	<b>Offset Y</b>
Name Space	SFNC
Firmware Release	00
Visibility	Beginner
Access	Read-Write
Type	Integer
Values	<b>Minimum:</b> 0 <b>Maximum:</b> <i>SensorHeight – Height</i> <b>Increment:</b> 2
<b>Name</b>	<b>PixelFormat</b>
Display Name	<b>Pixel Format</b>
Name Space	SFNC
Firmware Release	00
Visibility	Beginner
Access	Read-Write
Type	Enumeration
Values	<i>Mono8</i> – The camera outputs 8 bits per pixel <i>Mono10</i> – The camera outputs 10 bits per pixel. Available only when camera set to output 8 Cameralink taps
<b>Name</b>	<b>PixelColorFilter</b>
Display Name	<b>Pixel Color Filter</b>
Name Space	SFNC
Firmware Release	00
Visibility	Beginner
Access	Read-Only
Type	Enumeration
Values	<i>None</i>
Notes	No color filtering is available
<b>Name</b>	<b>PixelCoding</b>
Display Name	<b>Pixel Color Filter</b>
Name Space	SFNC
Firmware Release	00
Visibility	Beginner
Access	Read-Only
Type	Enumeration
Values	<i>Mono</i> – Monochrome pixel data
Notes	Output image pixel coding format of the sensor.
<b>Name</b>	<b>PixelSize</b>
Display Name	<b>Pixel Color Filter</b>
Name Space	SFNC
Firmware Release	00
Visibility	Beginner
Access	Read-Only
Type	Enumeration
Values	<i>Bpp8</i> – 8 bits per pixel <i>Bpp10</i> - 10 bits per pixel

<b>Name</b>	<b>TestImageSelector</b>
Display Name	<b>Test Image Selector</b>
Name Space	SFNC
Firmware Release	00
Visibility	Beginner
Access	Read-Write
Type	Enumeration
Values	<i>Off</i> - Image is from the camera sensor. <i>GreyHorizontalRamp</i> , <i>GreyVerticalRamp</i> , <i>Purity</i> , <i>GrayDiagonalRamp</i> , <i>FPN DiagonalRamp</i> ., <i>PRNU</i> , <i>SensorStaticPattern1</i> , <i>SensorDynamicPattern1</i> , <i>StaticValue</i> ., <i>FPN Coefficients</i> , <i>Color</i>
Notes	See the Test Patterns section for more information. Flatfield correction will be disabled if the user selects the <i>FPN Coefficients</i> value
<b>Name</b>	<b>testImageStaticValue</b>
Display Name	<b>Test Image Static Value</b>
Name Space	Custom
Firmware Release	00
Visibility	Beginner
Access	Read-Write when <i>TestImageSelector</i> is either <i>PRNU</i> , or <i>StaticValue</i>
Type	Integer
Values	0 to 1023
Notes	This feature allows the user to input a specific numeric value for use with the currently selected test image pattern, if it is needed
<b>Name</b>	<b>multipleAOIMode</b>
Display Name	[Enable] <b>Multiple AOI Mode</b>
Name Space	Custom
Firmware Release	00
Visibility	Guru
Access	Read-Write
Type	Enumeration
Values	<i>Active</i> – Multiple area of interest mode is active <i>Off</i> – Multiple area of interest mode is not active. Use single AOI.
Notes	[Preliminary] Enables or disables the multiple area of interest mode
<b>Name</b>	<b>multipleAOICount</b>
Display Name	<b>Multiple AOI Count</b>
Name Space	Custom
Firmware Release	00
Visibility	Guru
Access	Read-Write when <i>multipleAOIMode</i> is <i>Active</i>
Type	Integer
Values	2 to 16
Notes	[Preliminary] Gets/ Sets the number of areas of interest
<b>Name</b>	<b>multipleAOISelector</b>
Display Name	<b>Multiple AOI Selector</b>
Name Space	Custom
Firmware Release	00
Visibility	Guru
Access	Read-Write when <i>multipleAOIMode</i> is <i>Active</i>
Type	Integer
Values	1 to 16
Notes	[Preliminary] Selects which area of interest to view/ modify.

<b>Name</b>	<b>multipleAOIWidth</b>
Display Name	[Multiple] AOI Width
Name Space	Custom
Firmware Release	00
Visibility	Guru
Access	Read-Write when <i>multipleAOIMode</i> is Active
Type	Integer
Values	Minimum: 0 Maximum: ( <i>SensorWidth</i> – <i>multipleAOIOffsetX</i> ) Increment: 128
Notes	[Preliminary] Specifies the width for all of the multiple areas of interest.
<b>Name</b>	<b>multipleAOIHeight</b>
Display Name	[Multiple] AOI Height
Name Space	Custom
Firmware Release	00
Visibility	Guru
Access	Read-Write when <i>multipleAOIMode</i> is Active
Type	Integer
Values	Minimum: 0 Maximum: ( <i>SensorHeight</i> – <i>multipleAOIOffsetY</i> ) Increment: 2
Notes	[Preliminary] Specifies the height of the area of interest specified by <i>multipleAOISector</i> .
<b>Name</b>	<b>multipleAOIOffsetX</b>
Display Name	[Multiple] AOI Offset X
Name Space	Custom
Firmware Release	00
Visibility	Guru
Access	Read-Write when <i>multipleAOIMode</i> is Active
Type	Integer
Values	Minimum: 0 Maximum: ( <i>SensorHeight</i> – <i>multipleAOIWidth</i> ) Increment: 2
Notes	[Preliminary] Specifies the horizontal offset for all of the areas of interest.
<b>Name</b>	<b>multipleAOIOffsetY</b>
Display Name	[Multiple] AOI Offset Y
Name Space	Custom
Firmware Release	00
Visibility	Guru
Access	Read-Write when <i>multipleAOIMode</i> is Active
Type	Integer
Values	Minimum: 0 Maximum: ( <i>SensorHeight</i> – <i>multipleAOIHeight</i> ) Increment: 2
Notes	[Preliminary] Specifies the vertical offset of the area of interest specified by <i>multipleAOISector</i> .

## Invisible Features

<b>Name</b>	<b>streamingWidth, streamingHeight, streamingOffsetX, streamingOffsetY</b>
Name Space	Custom
Firmware Release	04
Visibility	Invisible
Access	Read-Write
Type	Integer
Values	Same as corresponding feature without the streaming prefix(e.g. Width)
Notes	Internal use. To implement feature streaming

Name	streamingPixelFormat
Name Space	Custom
Firmware Release	04
Visibility	Invisible
Access	Read-Write
Type	Enumeration
Values	Same as Pixel Format
Notes	Internal use. To implement feature streaming

## Test Patterns

When setting test patterns, the camera set the digital gains to 1x, the digital offsets to 0, and deactivates the flat field correction. This ensures that the test patterns appear as they should. At the same time, the camera saves the last set of values that were used for video processing and restores them when video output is restored.

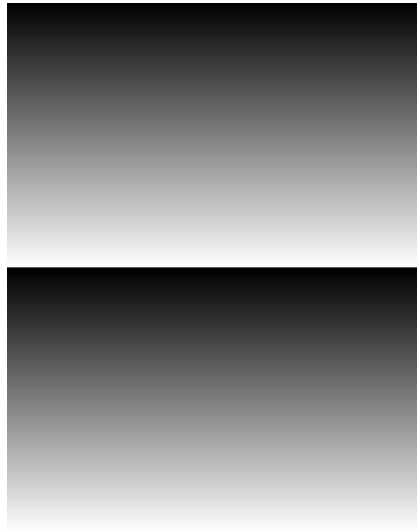
### Description

**Grey Horizontal Ramp:** Image is filled horizontally with an image that goes from the darkest possible value to the brightest. The ramp repeats every 1024 horizontal pixels.



**Figure 29 Gray Horizontal Ramp(not to scale)**

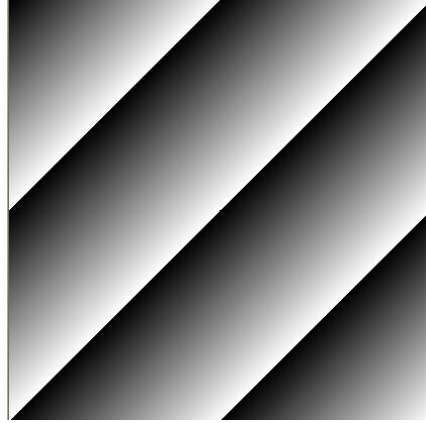
**Grey Vertical Ramp:** Image is filled vertically with an image that goes from the darkest possible value to the brightest. The ramp repeats every 1024 vertical pixels.



**Figure 30 Gray Vertical Ramp(not to scale)**

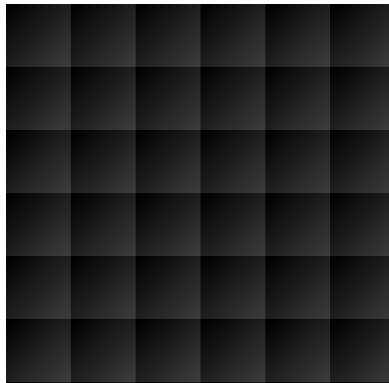
**Purity:** Image is filled with an image that goes from the darkest possible value to the brightest by 1 DN increment per frame (10-bit output).

**Gray Diagonal Ramp:** This test pattern is the sum of the horizontal and vertical test patterns.

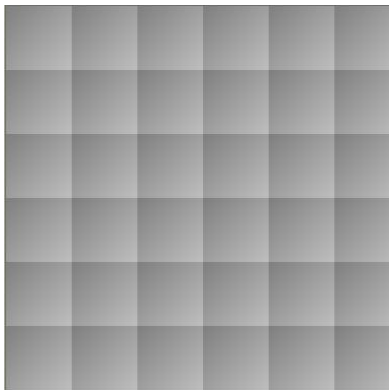


**Figure 31 Gray Horizontal Ramp(not to scale)**

FPN Diagonal Ramp: This is the sum of a horizontal test pattern that repeats every 64 pixels and a vertical test pattern that repeats every 62 lines. This test pattern can be used to test FPN correction.



PRNU: This test pattern is the sum of  $2 * (\text{FPN diagonal ramp}) + \text{testImageStaticValue}$ . This test pattern can be used to test PRNU correction.



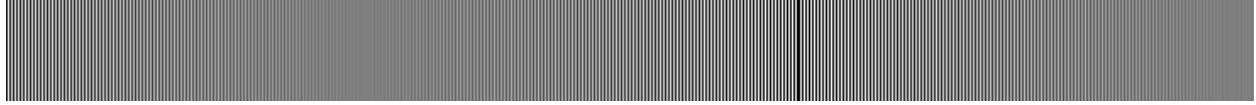
SensorStaticPattern1: This test pattern originates in the sensor and consists of two alternating vertical lines. The value depends on the *PixelFormat* and *pixelSizeInput*.



SensorDynamicPattern1: This test pattern originates in the sensor and consists of two interleaved vertical ramps. The first ramp increases by 1 DN to the maximum. The second ramp decreases by 1 DN until it



reaches 0. The starting values are determined by the sensor so changing the area of interest will change these values..



Static Value: All pixels are set to *testImageStaticValue*

FPN Coefficients: The flatfield Offset (FPN) values of the currently selected flatfield set are displayed.

Color: The image is tiled with squares that are 64 pixels wide. Each square tile is filled horizontally and vertical with pixels of each colors increasing at different rates. Additionally Bayer decoding may modify the values at the edges of the tile.

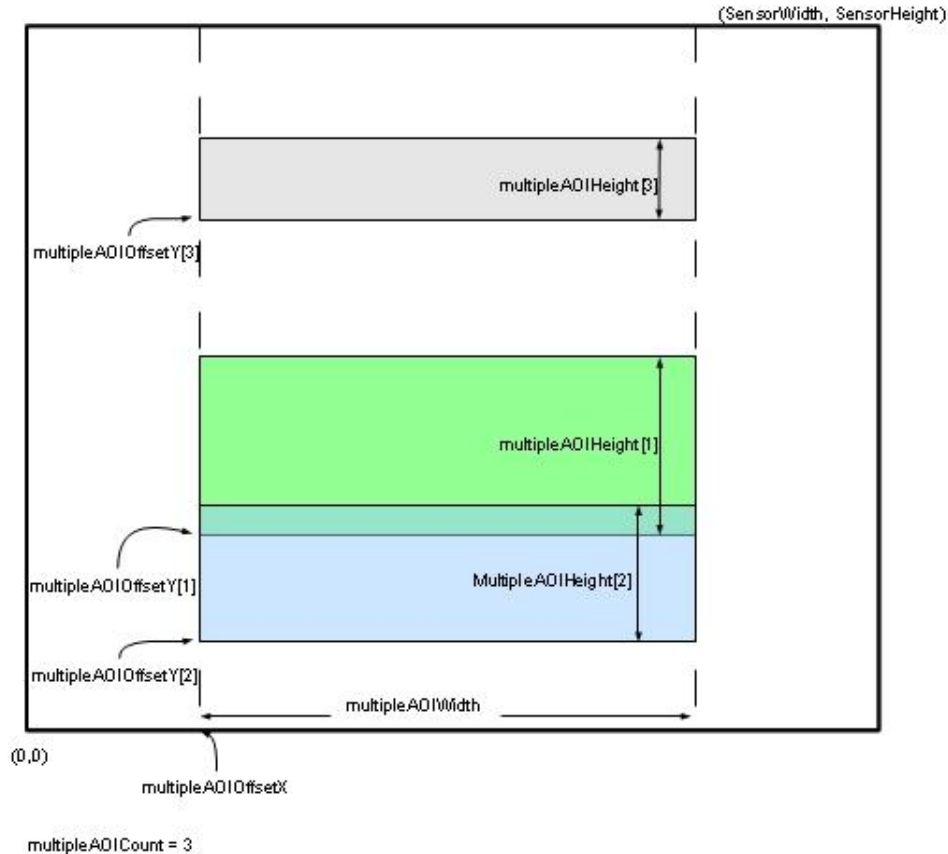
## Multiple AOI Mode

Use the **Multiple AOI commands** to define multiple areas of interest. Once defined, each of the AOIs share a common width and x-offset value. That is, all the allowable windows you define will have the same pixel width and the same starting coordinate (x-offset value). Within these defined parameters you are free to set the height and y-offset values, including overlapping height values. Up to 16 windows are permitted. The maximum frame rate will be dependent on the total size of the selected AOIs (See Figure 32).

### To specify multiple areas of interest:

**GenICam parameters > Image Format Controls:**

1. Set the **Multiple AOI Mode > Active**.
2. In the **Multiple AOI Count >** set to the total number of windows you want (minimum of 2, maximum of 16).
3. Select one of the AOIs from Step 2 to define, using the **Multiple AOI Selector**.
4. Set the Width and Height of the selected AOI, using the **Multiple AOI Width and Height parameters**.
5. Set the Offset X and Offset Y values of the select AOI, using the **Multiple AOI Offset X and Offset Y parameters**.
6. Choose another AOI to define, using the **Multiple AOI Selector**.
7. Repeat Steps 4 to 6 for each AOI. Note: the Width and the Offset X parameters are constant for each AOI. Changing them for one of the select AOIs will automatically change them for the others in the set.



**Figure 32 Multiple Areas of Interest**

Note: Overlapping regions will be combined.

## Camera Link Transport Layer Category

The camera's Camera Link Transport Layer category groups parameters used to document and configure the Camera Link output of the camera.

Parameters in gray are read only, either always or due to another parameter being disabled. Parameters in black are user set in CamExpert or programmable via an imaging application.

Features listed in the description table but tagged as *Invisible* are usually for Teledyne DALSA Support or third party software usage—and are not typically required by end user applications.

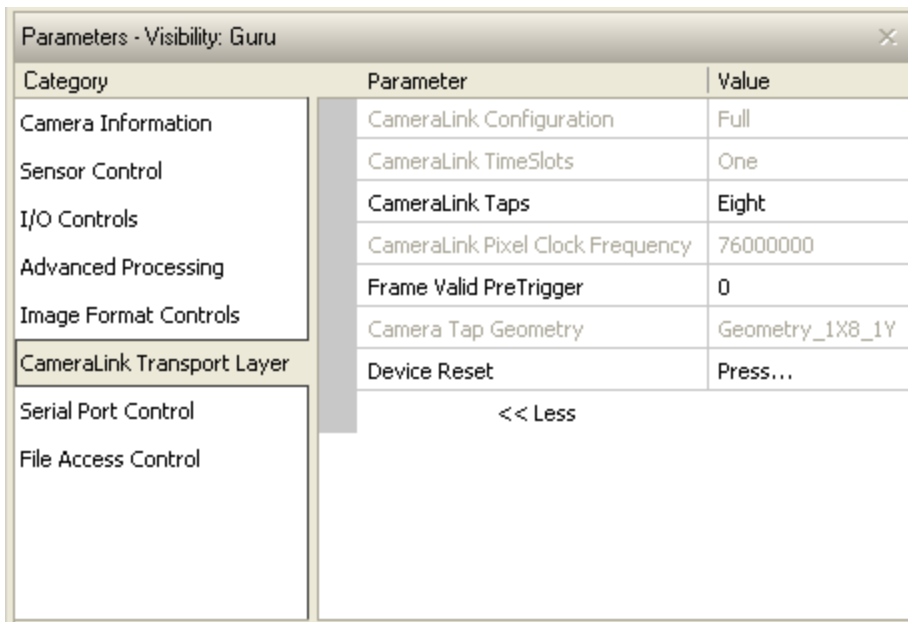


Figure 33 CameraLink Transport Layer as shown in CamExpert

## CameraLink Transport Layer Feature Description

The following table describes the category's parameters along with their view attribute and minimum camera firmware version required. Additionally the table will indicate which parameter is a member of the DALSA Features Naming Convention (DFNC), GenICam Standard Features Naming Convention, or a custom camera feature.

<b>Name</b>	<b>CIConfiguration</b>
Display Name	<b>CameraLink Configuration</b>
Name Space	DFNC
Firmware Release	00
Visibility	Beginner
Access	Read-Only
Type	Enumeration
Values	Full - Standard full configuration described by the Camera Link standard.</ Description>. Deca - Standard Deca configuration with 10 taps / 8-bit, as described by the Camera Link Standard.
Notes	Describes the camera's current CameraLink configuration.
<b>Name</b>	<b>CITimeSlotsCount [TBC]</b>
Display Name	<b>CameraLink TimeSlots</b>
Name Space	DFNC
Firmware Release	00
Visibility	Beginner
Access	Read-Only
Type	Enumeration
Values	One – All camera tap data is sent in one time slot.
Notes	Displays the number of consecutive time slots required for one complete data transfer of all camera taps. For example, when sending 4 taps over a 2 tap configuration, the required number of timeslots is 2.

<b>Name</b>	<b>deviceTapCount</b>
Display Name	<b>CameraLink Taps</b>
Name Space	DFNC
Firmware Release	00
Visibility	Beginner
Access	Read-Write
Type	Enumeration
Values	Eight – The camera outputs 8 Taps Ten – The camera outputs 10 Taps
Notes	Number of physical CameraLink taps in the camera in the current configuration.
<b>Name</b>	<b>clDeviceClockFrequency</b>
Display Name	<b>CameraLink Pixel Clock Frequency</b>
Name Space	DFNC
Firmware Release	00
Visibility	Beginner
Access	Read-Only
Type	Integer
Units	Hz
Values	76000000
Notes	The frequency of the clock on the CameraLink cables.
<b>Name</b>	<b>clFrameValidPreTrigger</b>
Display Name	<b>Frame Valid PreTrigger</b>
Name Space	Custom
Firmware Release	05
Visibility	Guru
Access	Read-Write
Type	Integer
Values	0 to 15
Notes	Some third party frame grabbers require that the FVAL and the first LVAL are separated by a given amount of time. This feature sets the number of clocks to add to the FVAL transition before the LVAL goes high.  This feature is not necessary for Teledyne DALSA frame grabbers.
<b>Name</b>	<b>clSmoothLineValidTiming</b>
Display Name	<b>Smooth Line Valid Timing</b>
Name Space	Custom
Firmware Release	05
Visibility	Guru
Access	Read-Write
Type	Enumeration
Values	Disable - Line Valid signal is not regulated Enable - Line Valid signal is regulated to come out of the camera at regular intervals.
Notes	Some third party frame grabbers require that the LVAL signal be at regular intervals. This feature regulates the sensor's LVAL signal to produce a regular signal train.  This feature is not necessary for Teledyne DALSA frame grabbers.

<b>Name</b>	<b>DeviceTapGeometry</b>
Display Name	<b>Device Tap Geometry</b>
Name Space	SFNC
Firmware Release	00
Visibility	Beginner
Access	Read-Write
Type	Enumeration
Values	<p><i>Geometry_IX8_IY</i> - 8 tap area scan, with 1 zone in X with 8 alternating taps &amp; 1 zone in Y.</p> <ul style="list-style-type: none"> <li>• Tap 1 starts with pixel coordinate (1,1), extending to the image width -1 and height, using a step of 8 (that is x = 1, 9, 17,...).</li> <li>• Tap 2 starts with pixel coordinate (2,1), extending to the image width and height, using a step of 8 (that is, x = 2, 10, 18, ...).</li> <li>• Etc.</li> </ul> <p><i>Geometry_IX10_IY</i> - 10 tap area scan, with 1 zone in X with 10 alternating taps &amp; 1 zone in Y.</p> <ul style="list-style-type: none"> <li>• Tap 1 starts with pixel coordinate (1,1), extending to the image width -1 and height, using a step of 10 (that is x = 1, 11, 21,...).</li> <li>• Tap 2 starts with pixel coordinate (2,1), extending to the image width and height, using a step of 10 (that is, x = 2, 12, 22, ...).</li> <li>• Etc.</li> </ul>
Notes	The tap geometry describes the geometrical properties characterizing the different taps of a multi-tap camera.
<b>Name</b>	<b>DeviceReset</b>
Display Name	<b>Device Reset</b>
Name Space	SFNC
Firmware Release	00
Visibility	Beginner
Access	Read-Write
Type	Command
Notes	Currently the camera will send a response to this command because it is resetting itself. This will result in an error in the host application.

## Invisible Features

<b>Name</b>	<b>streamingDeviceTapCount</b>
Name Space	<b>Custom</b>
Firmware Release	05
Visibility	Invisible
Access	Beginner
Type	Enumeration
Values	Same as deviceTapCount
Notes	Internal use. Used to support streaming

# Serial Port Control Category

Parameters in gray are read only, either always or due to another parameter being disabled. Parameters in black are user set in CamExpert or programmable via an imaging application.

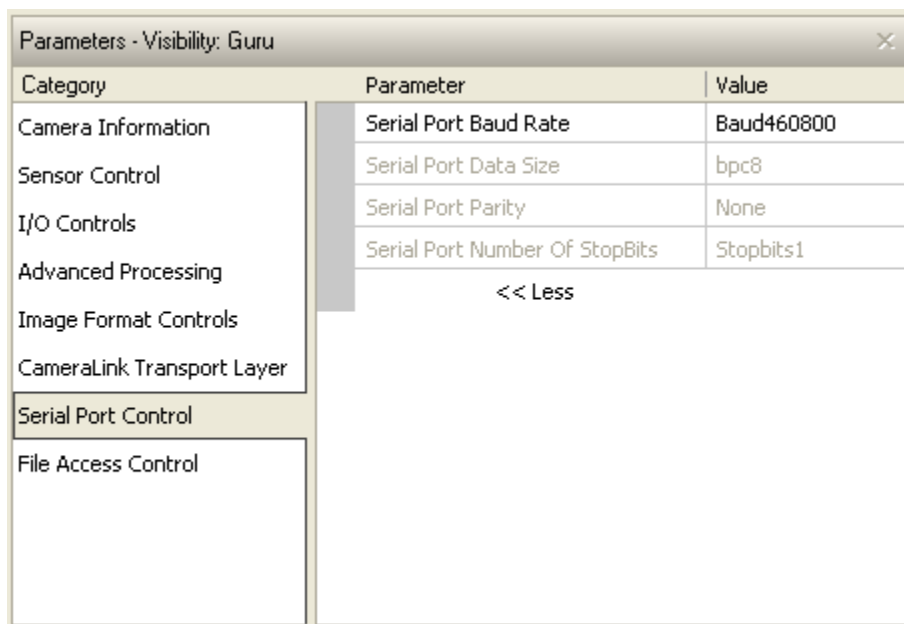


Figure 34 Serial Port control Category in CamExpert

## Feature Description

The following table describes the category's parameters along with their view attribute and minimum camera firmware version required. Additionally the table will indicate which parameter is a member of the DALSA Features Naming Convention (DFNC), GenICam Standard Features Naming Convention or a custom camera feature.

Name	DeviceSerialPortBaudRate
Display Name	<b>Serial Port Baud Rate</b>
Name Space	DFNC
Firmware Release	00
Visibility	Beginner
Access	Read-Write
Type	Enumeration
Values	9600 19200 57600 115200 230400 460800
Notes	The Falcon2 camera will always boot in 9600 baud.  In firmware version 4 and later, the camera automatically saves the baud rate in non-volatile memory and will try to use that speed to communicate after the next power cycle.  See Automatic Serial Speed Detection for information about how the serial speed is determined.
Name	deviceSerialPortDataSize

Display Name	<b>Serial Port Data Size</b>
Name Space	DFNC
Firmware Release	00
Visibility	Beginner
Access	Read-Only
Type	Enumeration
Values	bcp8 -8 bits per character
Notes	The number of bits that transmit a single character
<b>Name</b>	<b>deviceSerialPortParity</b>
Display Name	<b>Serial Port Parity</b>
Name Space	DFNC
Firmware Release	00
Visibility	Beginner
Access	Read-Only
Type	Enumeration
Values	None – no parity
Notes	
<b>Name</b>	<b>deviceSerialPortNumberOfStopBits</b>
Display Name	Serial Port Number Of StopBits
Name Space	DFNC
Firmware Release	00
Visibility	Beginner
Access	Read-Only
Type	Enumeration
Values	Stopbits1 – stop bit
Notes	The number of bits used to indicate that a character has been transmitted.

## Automatic Serial Speed Detection

In order for the camera and the frame grabber to communicate they both must be set to the same baud rate (serial speed).

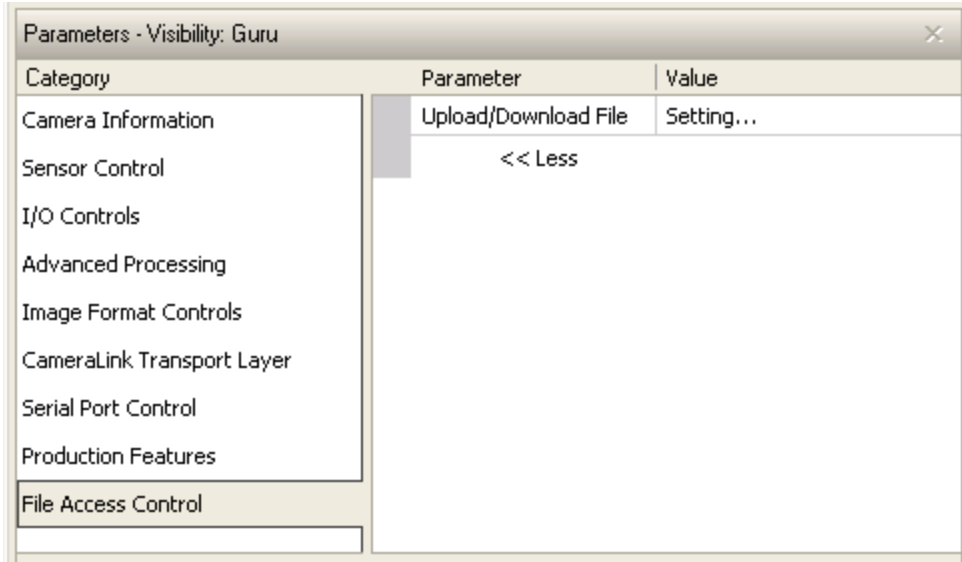
The serial protocol automatically detects the speed of camera by the following steps:

1. Set the serial speed of the frame grabber and send a command to the camera
2. If the camera doesn't respond after a defined time, then repeat step 1.
3. Once communication has been established the camera will set the serial speed to the maximum value that both the camera and frame grabber can support (firmware versions 0 to 3).

In firmware version 4 or later, the maximum value will be the previously set value of the *DeviceSerialPortBaudRate* feature.

## File Access Control Category

The File Access control in CamExpert allows the user to quickly upload various data files to the connected Falcon2. The supported data files are for Falcon2 firmware updates, Flat Field coefficients, and files to debug the camera.



**Figure 35 File Access Control Category in CamExpert**

<b>Name</b>	<b>FileSelector</b>
Display Name	<b>File Selector</b>
Name Space	SFNC
Firmware Release	00
Visibility	Beginner
Access	Read-Write
Type	Enumeration
Values	<p><i>Firmware:</i> [Write-Only] Writing a new firmware here will update the camera.</p> <p><i>UserFlatfieldCoefficients1:</i> Previously saved flat field coefficients (i.e. gain and offset).</p> <p><i>UserFlatfieldCoefficients2:</i> Previously saved flat field coefficients (i.e. gain and offset).</p> <p><i>UserFlatfieldCoefficients3:</i> Previously saved flat field coefficients (i.e. gain and offset).</p> <p><i>UserFlatfieldCoefficients4:</i> Previously saved flat field coefficients (i.e. gain and offset).</p> <p><i>Logs:</i> [Read-Only] Download camera logs. This is a zipped file.</p> <p><i>CameraSettings:</i> [Read-Only] Download camera settings. This is a html file. Please save with a htm extension.</p> <p><i>TestFile:</i> Dummy read and write file.</p>
Notes	Selects the file to access. The file types which are accessible are device dependent.
<b>Name</b>	<b>FileOperationSelector</b>
Display Name	<b>File Operation Selector</b>
Name Space	SFNC
Firmware Release	00
Visibility	Beginner
Access	Read-Write
Type	Enumeration
Values	<p><i>Open:</i> Select the Open operation - executed by FileOperationExecute.</p> <p><i>Close:</i> Select the Close operation - executed by FileOperationExecute.</p> <p><i>Read:</i> Select the Read operation - executed by FileOperationExecute.</p> <p><i>Write:</i> Select the Write operation - executed by FileOperationExecute</p> <p><i>Delete:</i> Select the Delete operation - executed by FileOperationExecute</p>
Notes	Selects the target operation for the selected file in the device. This operation is executed when the File Operation Execute feature is called.

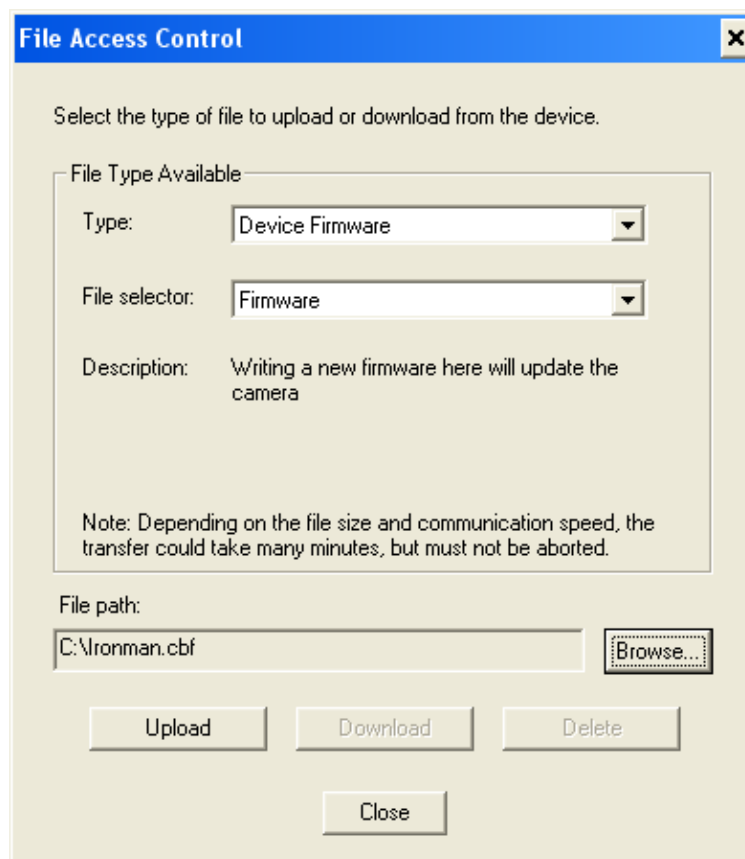


<b>Name</b>	<b>FileOperationExecute</b>
Display Name	<b>File Operation Execute</b>
Name Space	SFNC
Firmware Release	00
Visibility	Beginner
Access	Read-Write
Type	Command
Notes	Executes the operation selected by File Operation Selector on the selected file.
<b>Name</b>	<b>FileOpenMode</b>
Display Name	<b>File Open Mode</b>
Name Space	SFNC
Firmware Release	00
Visibility	Beginner
Access	Read-Write
Type	Enumeration
Values	<i>Read:</i> Select READ only open mode <i>Write:</i> Select WRITE only open mode
Notes	Selects the access mode used to open a file on the device.
<b>Name</b>	<b>FileAccessBuffer</b>
Display Name	<b>File Access Buffer</b>
Name Space	SFNC
Firmware Release	00
Visibility	Beginner
Access	Read-Write
Type	Enumeration
Notes	Defines the intermediate access buffer that allows the exchange of data between the device file storage and the application.
<b>Name</b>	<b>FileAccessOffset</b>
Display Name	<b>File Access Offset</b>
Name Space	SFNC
Firmware Release	00
Visibility	Beginner
Access	Read-Write
Type	Enumeration
Values	0 to ( <i>FileSize</i> -1) or 16777216, whichever value is smaller.
Notes	Controls the mapping offset between the device file storage and the file access buffer.
<b>Name</b>	<b>FileAccessLength</b>
Display Name	<b>File Access Length</b>
Name Space	SFNC
Firmware Release	00
Visibility	Beginner
Access	Read-Write
Type	Enumeration
Values	1 to Maximum size of <i>FileAccessBuffer</i>
Notes	Controls the mapping length between the device file storage and the file access buffer.
<b>Name</b>	<b>File Operation Status</b>
Display Name	<b>File Operation Status</b>
Name Space	SFNC
Firmware Release	00
Visibility	Beginner
Access	Read-Only
Type	Enumeration
Values	<i>Success</i> : The last file operation has completed successfully. <i>Failure</i> :The last file operation has completed unsuccessfully for an unknown reason. <i>FileUnavailable</i> :The last file operation has completed unsuccessfully because the file is currently unavailable. <i>FileInvalid</i> : The last file operation has completed unsuccessfully because the selected file in

	not present in this camera model.
Notes	Selects the access mode used to open a file on the device.
Name	<b>FileOperationResult</b>
Display Name	<b>File Operation Result</b>
Name Space	SFNC
Firmware Release	00
Visibility	Beginner
Access	Read-Only
Type	Enumeration
Notes	Displays the file operation result. For Read or Write operations, the number of successfully read/ written bytes is returned.
Name	<b>FileSize</b>
Display Name	<b>File Size</b>
Name Space	SFNC
Firmware Release	00
Visibility	Beginner
Access	Read-Write
Type	Enumeration
Notes	Represents the size of the selected file in bytes.

## File Access via the CamExpert Tool

1. Click on the “Setting...” button to show the file selection menu.



**Figure 36 Initial File Access Control Dialog**

2. From the Type drop menu, select the file type that will be uploaded to the camera.



3. From the File Selector drop menu, select the camera memory location for the uploaded data. This menu presents only the applicable data locations for the selected file type.



4. Click the Browse button to open a typical Windows Explorer window.
5. Select the specific file from the system drive or from a network location.
6. Click the Download button to execute the file transfer from the Falcon2.
7. Note that firmware changes require a device reset command.

# Appendix A: Camera Link

## Output Signals, Camera Link Clocking Signals

These signals indicate when data is valid, allowing you to clock the data from the camera to your acquisition system. These signals are part of the Camera Link configuration and you should refer to the Camera Link Implementation Road Map, available at our [Knowledge Center](#), for the standard location of these signals.

Clocking Signal	Indicates
LVAL (high)	Outputting valid line
DVAL	Not used, stuck low
STROBE (rising edge)	Valid data
FVAL (high)	Outputting valid frame

- The sensor internally digitizes to 10, 9, or 8 bits. The camera outputs the 8 most significant bits (MSB's) or all 10-bits depending on the Camera Link mode that the camera is operating in.

## Camera Link cable quality and length

The maximum allowable Camera Link cable length depends on the quality of the cable used and the Camera Link strobe frequency. Cable quality degrades over time as the cable is flexed. In addition, as the Camera Link strobe frequency is increased the maximum allowable cable length will decrease.

The cameras are capable of driving cables less than 7 metres in length. We do not guarantee good imaging performance with low quality cables of *any* length. In general, we recommend the use of high quality cables for any cable length.

### Recommended Cables

We recommend the use of high-quality mini-CL cables. Teledyne DALSA has 3 meter and 5 meter cables available as accessories. Contact Customer Support.

## Data Connector: Camera Link

The camera uses two mini-Camera Link SDR-26 cables transmitting the Camera Link Full or Extended configuration. The figure below shows the SDR-26 mini Camera Link Connector and the tables that follow list the Camera Link Full and Extended configurations.

For detailed information on Camera Link please refer to the Camera Link Road Map available from the Knowledge Center on the Teledyne DALSA Web site:

<http://www.teledynedalsa.com/mv/knowledge/appnotes.aspx>.

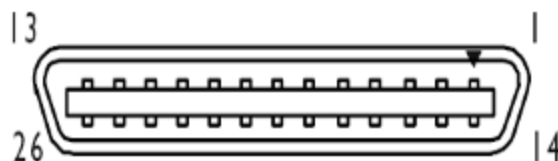


Figure 37: SDR-26 Mini Camera Link Connector

Data 2	Right Angle Frame Grabber Connector	Channel Link Signal	Control / Data 1	Right Angle Frame Grabber Connector	Channel Link Signal
1	1	inner shield	1	1	inner shield
14	14	inner shield	14	14	inner shield
2	25	Y0-	2	25	X0-
15	12	Y0+	15	12	X0+
3	24	Y1-	3	24	X1-
16	11	Y1+	16	11	X1+
4	23	Y2-	4	23	X2-
17	10	Y2+	17	10	X2+
5	22	Yclk-	5	22	Xclk-
18	9	Yclk+	18	9	Xclk+
6	21	Y3-	6	21	X3-
19	8	Y3+	19	8	X3+
7	20	100 ohm	7	20	SerTC+
20	7	terminated	20	7	SerTC-
8	19	Z0-	8	19	SerTFG-
21	6	Z0+	21	6	SerTFG+
9	18	Z1-	9	18	CC1-
22	5	Z1+	22	5	CC1+
10	17	Z2-	10	17	CC2+
23	4	Z2+	23	4	CC2-
11	16	Zclk-	11	16	CC3-
24	3	Zclk+	24	3	CC3+
12	15	Z3-	12	15	CC4+
25	2	Z3+	25	2	CC4-
13	13	inner shield	13	13	inner shield
26	26	inner shield	26	26	inner shield

\*Exterior Overshield is connected to the shells of the connectors on both ends. Unused pairs should be terminated in 100 ohms at both ends of the cable. Inner shield is connected to signal ground inside camera

## Full Configuration

### 8 taps 8 bits Camera link Full configuration

Connector 1: Channel link X		Connector 2: Channel link Y		Connector 3: Channel link Z	
Camera/Frame Grabber Pin	Bit Name	Camera/Frame Grabber Pin	Bit Name	Camera/Frame Grabber Pin	Bit Name
Tx0/Rx0	D0(0)	Tx0/Rx0	D3(0)	Tx0/Rx0	D6(0)
Tx1/Rx1	D0(1)	Tx1/Rx1	D3(1)	Tx1/Rx1	D6(1)
Tx2/Rx2	D0(2)	Tx2/Rx2	D3(2)	Tx2/Rx2	D6(2)
Tx3/Rx3	D0(3)	Tx3/Rx3	D3(3)	Tx3/Rx3	D6(3)
Tx4/Rx4	D0(4)	Tx4/Rx4	D3(4)	Tx4/Rx4	D6(4)
Tx5/Rx5	D0(7)	Tx5/Rx5	D3(7)	Tx5/Rx5	D6(7)
Tx6/Rx6	D0(5)	Tx6/Rx6	D3(5)	Tx6/Rx6	D6(5)
Tx7/Rx7	D1(0)	Tx7/Rx7	D4(0)	Tx7/Rx7	D7(0)
Tx8/Rx8	D1(1)	Tx8/Rx8	D4(1)	Tx8/Rx8	D7(1)
Tx9/Rx9	D1(2)	Tx9/Rx9	D4(2)	Tx9/Rx9	D7(2)
Tx10/Rx10	D1(6)	Tx10/Rx10	D4(6)	Tx10/Rx10	D7(6)
Tx11/Rx11	D1(7)	Tx11/Rx11	D4(7)	Tx11/Rx11	D7(7)
Tx12/Rx12	D1(3)	Tx12/Rx12	D4(3)	Tx12/Rx12	D7(3)
Tx13/Rx13	D1(4)	Tx13/Rx13	D4(4)	Tx13/Rx13	D7(4)
Tx14/Rx14	D1(5)	Tx14/Rx14	D4(5)	Tx14/Rx14	D7(5)
Tx15/Rx15	D2(0)	Tx15/Rx15	D5(0)	Tx15/Rx15	Not Used
Tx16/Rx16	D2(6)	Tx16/Rx16	D5(6)	Tx16/Rx16	Not Used
Tx17/Rx17	D2(7)	Tx17/Rx17	D5(7)	Tx17/Rx17	Not Used
Tx18/Rx18	D2(1)	Tx18/Rx18	D5(1)	Tx18/Rx18	Not Used
Tx19/Rx19	D2(2)	Tx19/Rx19	D5(2)	Tx19/Rx19	Not Used
Tx20/Rx20	D2(3)	Tx20/Rx20	D5(3)	Tx20/Rx20	Not Used
Tx21/Rx21	D2(4)	Tx21/Rx21	D5(4)	Tx21/Rx21	Not Used
Tx22/Rx22	D2(5)	Tx22/Rx22	D5(5)	Tx22/Rx22	Not Used
Tx23/Rx23	Not Used	Tx23/Rx23	Not Used	Tx23/Rx23	Not Used
Tx24/Rx24	LVAL	Tx24/Rx24	LVAL	Tx24/Rx24	LVAL
Tx25/Rx25	FVAL	Tx25/Rx25	FVAL	Tx25/Rx25	FVAL
Tx26/Rx26	Not Used	Tx26/Rx26	Not Used	Tx26/Rx26	Not Used
Tx27/Rx27	D0(6)	Tx27/Rx27	D3(6)	Tx27/Rx27	D6(6)

Tap 1 bits are D0(x)...Tap 8 bits are D7(x)

## Extended Configurations

### 10 taps 8 bits Camera link Extended configuration

Connector 1: Channel link X		Connector 1: Channel link Y		Connector 1: Channel link Z	
Camera/Frame Grabber Pin	Bit Name	Camera/Frame Grabber Pin	Bit Name	Camera/Frame Grabber Pin	Bit Name
Tx0/Rx0	D0(0)	Tx0/Rx0	D3(2)	Tx0/Rx0	D6(5)
Tx1/Rx1	D0(1)	Tx1/Rx1	D3(3)	Tx1/Rx1	D6(6)
Tx2/Rx2	D0(2)	Tx2/Rx2	D3(4)	Tx2/Rx2	D6(7)
Tx3/Rx3	D0(3)	Tx3/Rx3	D3(5)	Tx3/Rx3	D7(0)
Tx4/Rx4	D0(4)	Tx4/Rx4	D3(6)	Tx4/Rx4	D7(1)
Tx5/Rx5	D0(5)	Tx5/Rx5	D3(7)	Tx5/Rx5	D7(2)
Tx6/Rx6	D0(6)	Tx6/Rx6	D4(0)	Tx6/Rx6	D7(3)
Tx7/Rx7	D0(7)	Tx7/Rx7	D4(1)	Tx7/Rx7	D7(4)
Tx8/Rx8	D1(0)	Tx8/Rx8	D4(2)	Tx8/Rx8	D7(5)
Tx9/Rx9	D1(1)	Tx9/Rx9	D4(3)	Tx9/Rx9	D7(6)
Tx10/Rx10	D1(2)	Tx10/Rx10	D4(4)	Tx10/Rx10	D7(7)
Tx11/Rx11	D1(3)	Tx11/Rx11	D4(5)	Tx11/Rx11	D8(0)
Tx12/Rx12	D1(4)	Tx12/Rx12	D4(6)	Tx12/Rx12	D8(1)
Tx13/Rx13	D1(5)	Tx13/Rx13	D4(7)	Tx13/Rx13	D8(2)
Tx14/Rx14	D1(6)	Tx14/Rx14	D5(0)	Tx14/Rx14	D8(3)
Tx15/Rx15	D1(7)	Tx15/Rx15	D5(1)	Tx15/Rx15	D8(4)
Tx16/Rx16	D2(0)	Tx16/Rx16	D5(2)	Tx16/Rx16	D8(5)
Tx17/Rx17	D2(1)	Tx17/Rx17	D5(3)	Tx17/Rx17	D8(6)
Tx18/Rx18	D2(2)	Tx18/Rx18	D5(4)	Tx18/Rx18	D8(7)
Tx19/Rx19	D2(3)	Tx19/Rx19	D5(5)	Tx19/Rx19	D9(0)
Tx20/Rx20	D2(4)	Tx20/Rx20	D5(6)	Tx20/Rx20	D9(1)
Tx21/Rx21	D2(5)	Tx21/Rx21	D5(7)	Tx21/Rx21	D9(2)
Tx22/Rx22	D2(6)	Tx22/Rx22	D6(0)	Tx22/Rx22	D9(3)
Tx23/Rx23	D2(7)	Tx23/Rx23	D6(1)	Tx23/Rx23	D9(4)
Tx24/Rx24	LVAL	Tx24/Rx24	D6(2)	Tx24/Rx24	D9(5)
Tx25/Rx25	FVAL	Tx25/Rx25	D6(3)	Tx25/Rx25	D9(6)
Tx26/Rx26	D3(0)	Tx26/Rx26	D6(4)	Tx26/Rx26	D9(7)
Tx27/Rx27	D3(1)	Tx27/Rx27	LVAL	Tx27/Rx27	LVAL

## 8 taps 10 bits Camera link Extended configuration

Connector 1: Channel link X		Connector 1: Channel link Y		Connector 1: Channel link Z	
Camera/Frame Grabber Pin	Bit Name	Camera/Frame Grabber Pin	Bit Name	Camera/Frame Grabber Pin	Bit Name
Tx0/Rx0	D0(2)	Tx0/Rx0	D3(2)	Tx0/Rx0	D6(2)
Tx1/Rx1	D0(3)	Tx1/Rx1	D3(3)	Tx1/Rx1	D6(3)
Tx2/Rx2	D0(4)	Tx2/Rx2	D3(4)	Tx2/Rx2	D6(4)
Tx3/Rx3	D0(5)	Tx3/Rx3	D3(5)	Tx3/Rx3	D6(5)
Tx4/Rx4	D0(6)	Tx4/Rx4	D3(6)	Tx4/Rx4	D6(6)
Tx5/Rx5	D0(9)	Tx5/Rx5	D3(9)	Tx5/Rx5	D6(9)
Tx6/Rx6	D0(7)	Tx6/Rx6	D3(7)	Tx6/Rx6	D6(7)
Tx7/Rx7	D1(2)	Tx7/Rx7	D4(2)	Tx7/Rx7	D7(2)
Tx8/Rx8	D1(3)	Tx8/Rx8	D4(3)	Tx8/Rx8	D7(3)
Tx9/Rx9	D1(4)	Tx9/Rx9	D4(4)	Tx9/Rx9	D7(4)
Tx10/Rx10	D1(8)	Tx10/Rx10	D4(8)	Tx10/Rx10	D7(8)
Tx11/Rx11	D1(9)	Tx11/Rx11	D4(9)	Tx11/Rx11	D7(9)
Tx12/Rx12	D1(5)	Tx12/Rx12	D4(5)	Tx12/Rx12	D7(5)
Tx13/Rx13	D1(6)	Tx13/Rx13	D4(6)	Tx13/Rx13	D7(6)
Tx14/Rx14	D1(7)	Tx14/Rx14	D4(7)	Tx14/Rx14	D7(7)
Tx15/Rx15	D2(2)	Tx15/Rx15	D5(2)	Tx15/Rx15	D2(1)
Tx16/Rx16	D2(8)	Tx16/Rx16	D5(8)	Tx16/Rx16	D5(1)
Tx17/Rx17	D2(9)	Tx17/Rx17	D5(9)	Tx17/Rx17	D6(0)
Tx18/Rx18	D2(3)	Tx18/Rx18	D5(3)	Tx18/Rx18	D3(0)
Tx19/Rx19	D2(4)	Tx19/Rx19	D5(4)	Tx19/Rx19	D3(1)
Tx20/Rx20	D2(5)	Tx20/Rx20	D5(5)	Tx20/Rx20	D4(0)
Tx21/Rx21	D2(6)	Tx21/Rx21	D5(6)	Tx21/Rx21	D4(1)
Tx22/Rx22	D2(7)	Tx22/Rx22	D5(7)	Tx22/Rx22	D5(0)
Tx23/Rx23	D0(1)	Tx23/Rx23	D2(0)	Tx23/Rx23	D7(1)
Tx24/Rx24	LVAL	Tx24/Rx24	LVAL	Tx24/Rx24	LVAL
Tx25/Rx25	FVAL	Tx25/Rx25	D1(0)	Tx25/Rx25	D6(1)
Tx26/Rx26	D0(0)	Tx26/Rx26	D1(1)	Tx26/Rx26	D7(0)
Tx27/Rx27	D0(8)	Tx27/Rx27	D3(8)	Tx27/Rx27	D6(8)



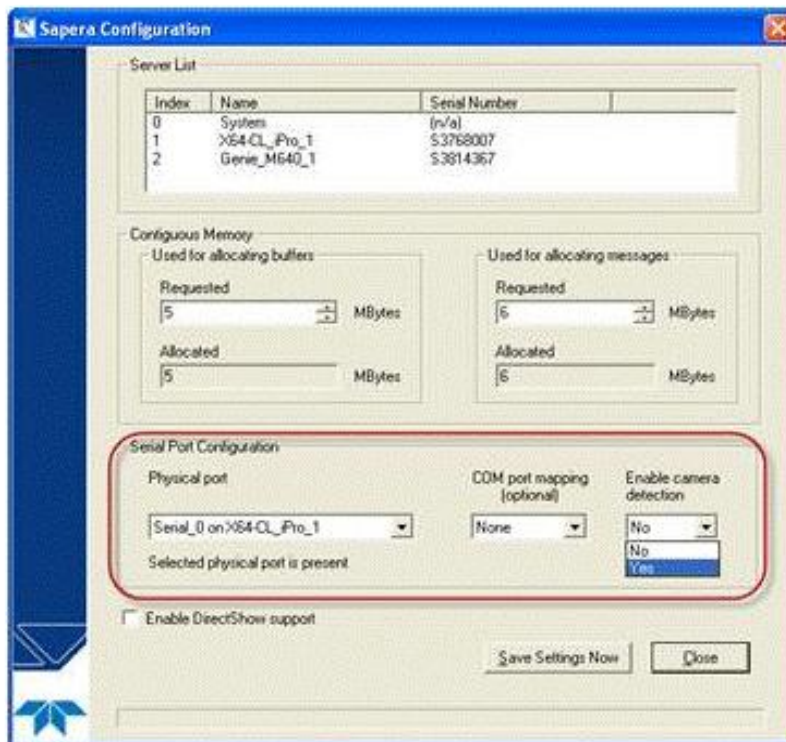
# Appendix B: Camera, Frame Grabber Communication

## Setting Up Communication between the Camera and the Frame Grabber

Teledyne DALSA Camera Link cameras support the GenCP CameraLink standards.

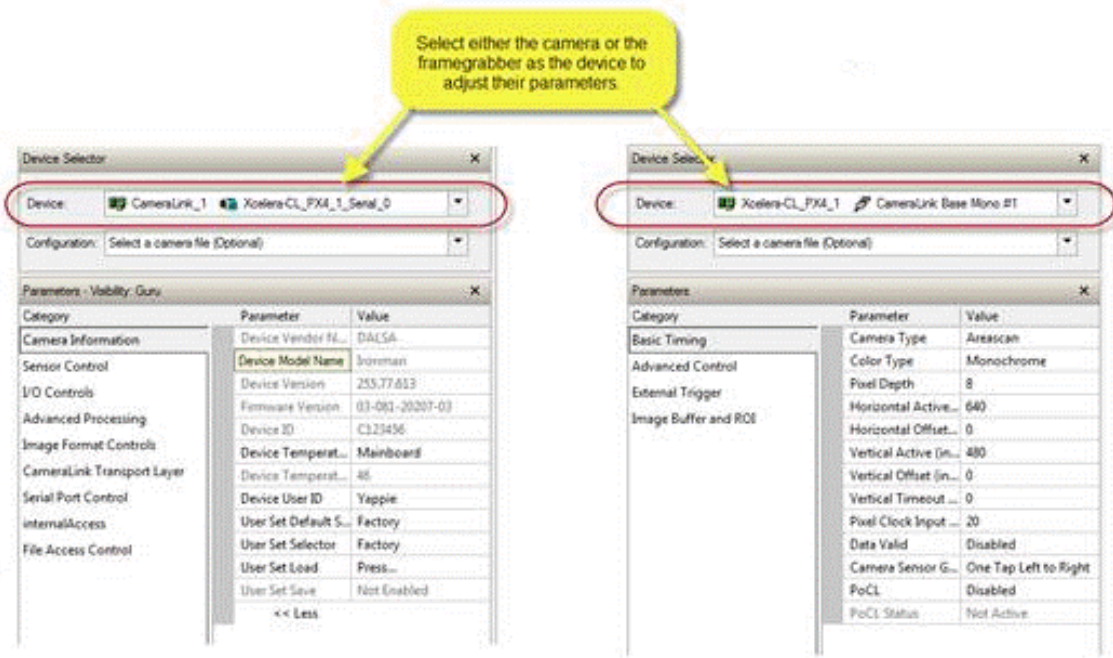
To configure Teledyne DALSA GenCP Camera Link Cameras:

1. Install the Teledyne DALSA frame grabber in the host computer; refer to the hardware installation manual
2. Install Sopera LT and the Teledyne DALSA frame grabber driver.
3. Connect the camera to the frame grabber; refer to the camera installation manual.
4. Run the Sopera Configuration utility, select the frame grabber serial port connected to the camera, and set the **Enable camera detection** parameter to **Yes**.



5. Start the CamExpert application. In the Device tab, select either the camera or frame grabber to adjust their parameters; currently, for GenCP cameras, the camera and frame grabber parameters

must be adjusted separately.



6. Modify the camera and frame grabber parameter settings as required, and test the image acquisition by clicking the **Grab** button.



7. Save the frame grabber configuration to a new \*.cf file.

---

# Appendix C: Cleaning the Sensor Window

## Recommended Equipment

- Glass cleaning station with microscope within clean room.
- 3M ionized air gun 980  
([http://solutions.3mcanada.ca/wps/portal/3M/en\\_CA/WW2/Country/](http://solutions.3mcanada.ca/wps/portal/3M/en_CA/WW2/Country/))
- Ionized air flood system, foot operated.
- Swab (HUBY-340CA-003)  
(<http://www.cleancross.net/modules/xfsection/article.php?articleid=24>)
- Single drop bottle (FD-2-ESD)
- E2 (Eclipse optic cleaning system ([www.photosol.com](http://www.photosol.com)))

## Procedure

- Use localized ionized air flow on to the glass during sensor cleaning.
- Blow off mobile contamination using an ionized air gun.
- Place the sensor under the microscope at a magnification of 5x to determine the location of any remaining contamination.
- Clean the contamination on the sensor using one drop of E2 on a swab.
- Wipe the swab from left to right (or right to left but only in one direction). Do this in an overlapping pattern, turning the swab after the first wipe and with each subsequent wipe. Avoid swiping back and forth with the same swab in order to ensure that particles are removed and not simply transferred to a new location on the sensor window. This procedure requires you to use multiple swabs.
- Discard the swab after both sides of the swab have been used once.
- Repeat until there is no visible contamination present.

---

# Appendix D: Internal Flat Field Calibration Algorithms

The Falcon2 camera provides the user with the ability to perform a custom flat field calibration. This appendix gives details of the calibration algorithms. All calibration is performed on averaged image data to reduce noise.

## Offset (FPN) Calibration

Offset calibration is performed when the sensor is not exposed to light. The offset values are calculated as follows:

- The camera averages several (see *flatfieldCalibrationSampleSize*) images.
- The offset correction is simply the average at each pixel.
- If the value is greater than the maximum correction (i.e. 127) then the pixel is marked for replacement and the number of hot pixels replaced is incremented (*flatfieldCalibrationHotPixelsReplaced*).
- If the value is equal to 0 then the number of clipped offset pixels is incremented (*flatfieldCalibrationOffsetPixelsClipped*).

## Pixel Replacement Calibration

Like the offset calibration, pixel replacement calibration is done when the sensor is not exposed to light. This calibration is used to find and replace pixels that turn “hot” at longer exposure times. Therefore, the calibration should be performed after the Offset calibration has been performed.

The Pixel replacement calibration is performed as follows:

- The camera averages several (see *flatfieldCalibrationSampleSize*) images.
- For each pixel
  - The offset correction value (FPN coefficient) is subtracted from the averaged pixel value.
  - If the difference is greater than the pixel replacement offset threshold (*flatfieldCalibrationPixelReplacementOffsetThreshold*) then the pixel is marked for replacement and the number of hot pixels replaced is incremented (*flatfieldCalibrationHotPixelsReplaced*).
  - In this way ‘new’ hot pixels that appear due to the longer exposure time are targeted.

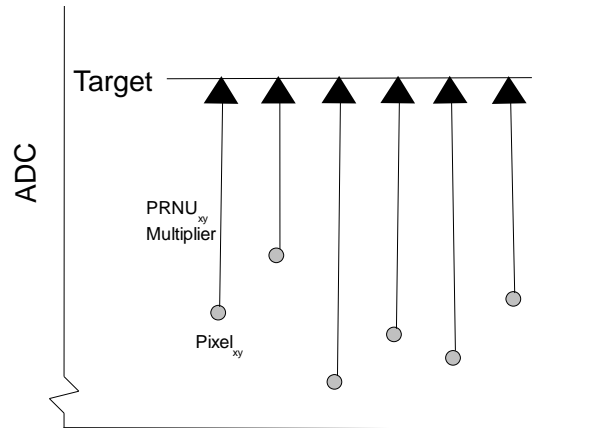
## Gain (PRNU) Calibration

The flat field gain calibration is performed after the offset calibration, when the sensor is exposed to flat light source. The gain on each pixel is adjusted to achieve a target value.

For the monochrome cameras the process is as follows:

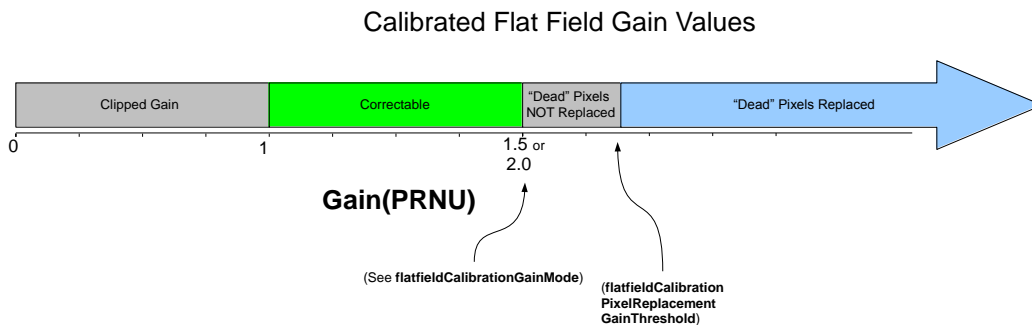
- The camera averages several (see *flatfieldCalibrationSampleSize*) images.
- For each pixel of the averaged image:
  - Subtract the previously calibrated offset values (FPN).

- Calculate the multiplication factor necessary to achieve the target value. The target value is calculated using *flatfieldCalibrationTarget*. See Figure 38.



**Figure 38 Monochrome Flat Field Gain Calibration**

- If the calculated gain is less than 1 then the number of clipped gain pixels (*flatfieldCalibrationGainPixelsClipped*) is incremented. A large number of clipped pixels may indicate a poorly chosen target or exposure setting.
- If the calculated pixel gain is greater than the pixel replacement threshold (see *flatfieldCalibrationPixelReplacementGainThreshold*) then the pixel is marked for replacement and the number of dead pixels replace is incremented (*flatfieldCalibrationDeadPixelsReplaced*). These pixels will have the maximum gain correction but will not reach the target. By default the replacement threshold is set to the highest correctable value so that the number of dead pixels that are not replaced is 0.
- If the calculated pixel gain is not correctable (i.e. greater than 1.5 or 2 when *flatfieldCalibrationGainMode* is *HighResolution* or *HighGain*) but less than the replacement threshold then the gain is set to maximum and the number of dead pixels not replaced is incremented (*flatfieldCalibrationDeadPixelsNotReplaced*)
- Once the gain values are calculated, the values are used to correct the image.



For the color cameras, the process is similar with the exception of the target value. For color cameras each color has its own target based on the average of each color multiplied by a factor (approx. 1.25). After each color is corrected the color gains are adjusted to set the pixels to the maximum color.

# Appendix E: Three Letter Commands

In addition to the GenICam interface, the Falcon2 camera supports the classic three letter command (TLC) interface. This method of controlling the camera may be preferable to customers with existing systems that use TLCs or who are using an operating system that is not supported by Spera or GenICam.

To access the TLC an ASCII-based communications interface application, such as HyperTerminal.

Additionally it is possible to use the functions of `clserxxx.dll` or `cllserial.dll` as defined in the Camera Link Specification.

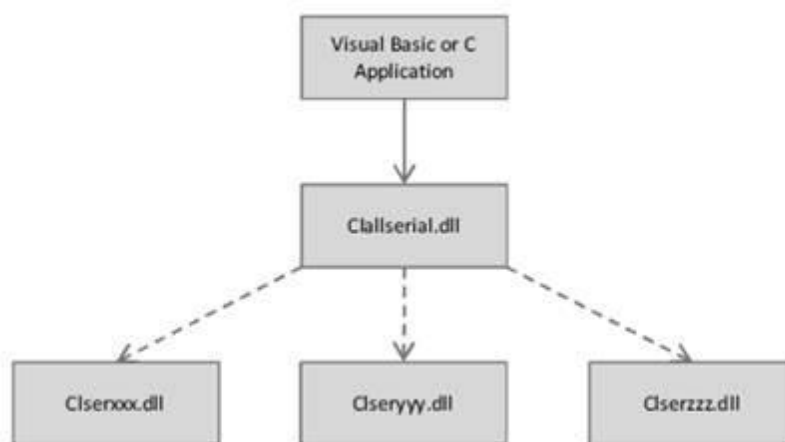


Figure 39 Serial DLL hierarchy as mentioned in the Camera Link Specification

## Putting Camera In TLC Mode

The camera boots up in GenICam(GenCP) mode at 9600 baud(8 bits No Parity 1 Stop Bit). To put the camera into three letter command mode:

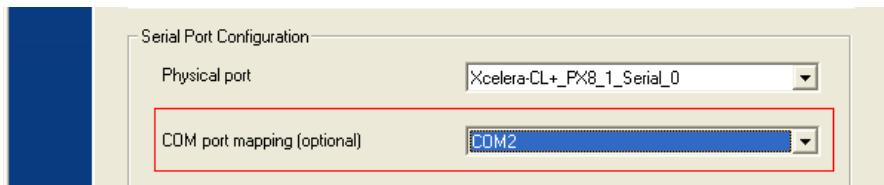
1. Power cycle the camera<sup>Note 1</sup>
2. Start a serial console application<sup>Note 2</sup>
3. Configure the camera link virtual serial port to:
  - 9600baud
  - 8 bits
  - No Parity
  - 1 Stop Bit
  - No flow control
 See the section titled Setting the Spera's COM Port Mapping
4. Configure the serial console to echo characters locally
5. Press the ESC key<sup>Note 3</sup>
6. An OK prompt should appear.

NOTES:

1. Some GenICam Software automatically adjusts the baud rate so if you are not power cycling or resetting the camera then you will need to determine the baud rate from the *DeviceSerialPortBaudRate*.
2. The Hyperterminal application is not available in the Windows 7 OS. The following alternative ASCII-interfaces have been tested and shown to work with this camera:  
TeraTerm: <http://logmett.com/index.php?download/tera-term-473-freeware.html>  
PuTTY: <http://putty.en.softonic.com/>
3. If you are using interfaces other than HyperTerminal, the ASCII character, ESC, is decimal 27 and needs to be issued. From the command line insert ESC by using ALT+2+7 of the activated Num-Pad. In some cases this needs to be followed by a carriage return or a linefeed to send this to the camera. In ASCII the ESC character may look like this: "\e".

## Setting the Sopera's COM Port Mapping

In order to access the TLCs the Camera Link software needs to map the Camera Link serial port to a virtual serial port on the host PC. In Sopera, use the Sopera Configuration Application to specify which of the PC's Com ports will be mapped to Camera Link.



## Getting Started

When the camera is in three letter command mode, it will send a prompt (i.e. >) to indicate that it is ready for input. If the previous command was successful then it will send an OK> prompt. If there was an error or warning then the prompt will indicate the nature of the problem (e.g. Unrecognized Command> ). To execute a command, you will enter the command name followed by relevant parameters and press enter. The command will execute and return the prompt when it is complete.

Note that the commands are case insensitive.

## The Help Command (h or ?)

To get a list of available command press h and then enter. This will list all of the commands available on the camera as well as a short description and the range of acceptable values. Additionally, the help command will display the text Not Available if the user is unable to use this command because of the setup of the camera. Sometimes the help information does not fit on a single line but the ? command will give more detailed help.

## Getting Parameters (gcp or get)

The gcp command provides a snapshot of all of the camera's settings. It is a good place to start to get familiar with the camera's capabilities and features. In addition to the gcp command, the get command provides a way to get the value associated with a given command (eg. get ssf returns the framerate).

# Commands

<b>Full Name</b>	area of interest - height	
<b>Mnemonic</b>	aih	
<b>Argument(s)</b>	height	2 to max height <ul style="list-style-type: none"> <li>• Max height determined by model and aspect ratio</li> <li>• in increments of 2</li> </ul>
<b>GenICam</b>	<i>Height</i>	
<b>Release</b>	6	
<b>Notes</b>	The values will be rounded to the nearest increment. Changing the aspect ratio will change the values of the AOI	

<b>Full Name</b>	area of interest - width	
<b>Mnemonic</b>	aiw	
<b>Argument(s)</b>	width	512 to max width <ul style="list-style-type: none"> <li>• Max width determined by model and aspect ratio</li> <li>• In increments of 128</li> </ul>
<b>GenICam</b>	<i>Width</i>	
<b>Release</b>	6	
<b>Notes</b>	The values will be rounded to the nearest increment. Changing the aspect ratio will change the values of the AOI	

<b>Full Name</b>	area of interest - offset y	
<b>Mnemonic</b>	aiy	
<b>Argument(s)</b>	offset	0 to (max height – Height) in increments of 2 <ul style="list-style-type: none"> <li>• Max height determined by model and aspect ratio</li> <li>• in increments of 2</li> </ul>
<b>GenICam</b>	<i>OffsetY</i>	
<b>Release</b>	6	
<b>Notes</b>	The values will be rounded to the nearest increment. Changing the aspect ratio will change the values of the AOI	

<b>Full Name</b>	area of interest - offset x	
<b>Mnemonic</b>	aiy	
<b>Argument(s)</b>	offset	0 to (max width – width) in increments of 128 <ul style="list-style-type: none"> <li>• Max height determined by model and aspect ratio</li> <li>• in increments of 128</li> </ul>
<b>GenICam</b>	<i>OffsetX</i>	
<b>Release</b>	6	
<b>Notes</b>	The values will be rounded to the nearest increment. Changing the aspect ratio will change the values of the AOI	

<b>Full Name</b>	calibrate fpn correction	
<b>Mnemonic</b>	ccf	
<b>GenICam</b>	<i>flatfieldCalibrationFPN</i>	
<b>Release</b>	6	
<b>Notes</b>	Only available when flat field mode is set to calibration ( i.e. ffm = CAL) May take several seconds to several minutes to complete See Appendix D: Internal Flat Field Calibration Algorithms for more information	

<b>Full Name</b>	camera link mode (taps)	
<b>Mnemonic</b>	clm	



<b>Argument(s)</b>	taps	8: 8 camera link taps 10: 10 camera link taps
<b>GenICam</b>	<i>deviceTapCount</i>	
<b>Release</b>	6	
<b>Notes</b>	The tap count must match what the framegrabber is expecting	

<b>Full Name</b>	calibrate prnu correction	
<b>Mnemonic</b>	cpa	
<b>Argument(s)</b>	target	The percentage of full scale to use as calibration target (monochrome models only)
	gain mode	The gain mode used in the calibration HG:High Gain HR:High Resolution
	Bad pixel threshold	The PRNU gain factor above which the pixel is marked defective. 1.50~7.99
<b>GenICam</b>	<i>flatfieldCalibrationPRNU</i> <i>flatfieldCalibrationTarget</i> <i>flatfieldCalibrationGainMode</i> <i>flatfieldCalibrationPixelReplacementGainThreshold</i>	
<b>Release</b>	6	
<b>Notes</b>	Only available when flat field mode is set to calibration ( i.e. ffm = CAL) May take several seconds to several minutes to complete depending on frame rate See Appendix D: Internal Flat Field Calibration Algorithms for more information	

<b>Full Name</b>	calibrate pixel replacement	
<b>Mnemonic</b>	cpr	
<b>Argument(s)</b>	threshold	Specifies the difference between offset(FPN) and average value(during pixel calibration), above which the pixel is marked as defective.
<b>GenICam</b>	<i>flatfieldCalibrationPixelReplacement</i> <i>flatfieldCalibrationPixelReplacementOffsetThreshold</i>	
<b>Release</b>	6	
<b>Notes</b>	Only available when flat field mode is set to calibration ( i.e. ffm = CAL) May take several seconds to several minutes to complete depending on frame rate See Appendix D: Internal Flat Field Calibration Algorithms for more information.	

<b>Full Name</b>	flatfield clear coefficients	
<b>Mnemonic</b>	fcc	
<b>GenICam</b>	<i>flatfieldCalibrationClearCoefficient</i>	
<b>Release</b>	6	
<b>Notes</b>	Only available when flat field mode is set to calibration ( i.e. ffm = CAL) Clears the current set selected by the <i>fsc</i> command	

<b>Full Name</b>	flatfield copy from		
<b>Mnemonic</b>	fcf		
<b>Argument(s)</b>	source	F: Copy from factory set 1: Copy from set 1 2: Copy from set 2 3: Copy from set 3 4: Copy from set 4	
	<b>GenICam</b>	<i>flatfieldCoefficientsCopyInCurrent</i>	
	<b>Release</b>	6	
	<b>Notes</b>	Only available when flat field mode is set to calibration ( i.e. ffm = CAL) There is a factory flat field set for every input pixel size.	

<b>Full Name</b>	flatfield set current F 1 2 3 4	
<b>Mnemonic</b>	fsc	
<b>Argument(s)</b>	current set	F: Set current to factory set 1: Set current to set 1 2: Set current to set 2 3: Set current to set 3 4: Set current to set 4
<b>GenICam</b>	<i>flatfieldCorrectionCurrentActiveSet</i>	
<b>Release</b>	6	
<b>Notes</b>	Only available when flat field mode is <u>not</u> set to calibration ( i.e. ffm != CAL)	

<b>Full Name</b>	flatfield display stats	
<b>Mnemonic</b>	fds	
<b>GenICam</b>	<i>flatfieldCalculatePixelStatistics</i> <i>flatfieldCalibrationGainPixelsClipped</i> <i>flatfieldCalibrationDeadPixelsNotReplaced</i> <i>flatfieldCalibrationOffsetPixelsClipped</i> <i>flatfieldCalibrationUncorrectableDeadPixels</i> <i>flatfieldCalibrationDeadPixelsReplaced</i> <i>flatfieldCalibrationUncorrectableHotPixels</i> <i>flatfieldCalibrationHotPixelsReplaced</i>	
<b>Release</b>	6	
<b>Notes</b>	Displays flatfield statistics. e.g.  OK>fds  Hot Pixels : 0 Uncorrectable Hot Pixels : 0 Dead Pixels Replaced : 19 Uncorrectable Dead Pixels: 123 Dead Pixels Not Replaced : 0 Offset Pixels Clipped : 2 Gain Pixels Clipped : 0 OK>^	

<b>Full Name</b>	flatfield mode	
<b>Mnemonic</b>	ffm	
<b>Argument(s)</b>	mode	OFF: No flatfield correction ALL: Apply both FPN and PRNU correction FPN: Apply FPN correction only PRNU: Apply PRNU correction only CAL: Put camera in calibration mode
<b>GenICam</b>	<i>flatfieldCorrectionMode</i>	
<b>Release</b>	6	
<b>Notes</b>	Calibration mode available only if <ul style="list-style-type: none"> <li>• current set is not factory(fsc != F)</li> <li>• width is greater than or equal to 2048</li> <li>• the camera is internally triggered( stm = i)</li> </ul>	

<b>Full Name</b>	flatfield set save	
<b>Mnemonic</b>	fss	
<b>GenICam</b>	<i>flatfieldCalibrationSave</i>	
<b>Release</b>	6	

<b>Notes</b>	Save the current flatfield calibration to non-volatile memory. Only available when flat field mode is set to calibration ( i.e. ffm = CAL)
--------------	---

<b>Full Name</b>	get camera model
<b>Mnemonic</b>	gcm
<b>GenICam</b>	<i>DeviceModelName</i>
<b>Release</b>	6
<b>Notes</b>	Returns a string containing the model name

<b>Full Name</b>	get camera parameters
<b>Mnemonic</b>	gcp
<b>Release</b>	6
<b>Notes</b>	<p>Returns a snap shot of the camera's settings e.g.</p> <pre> OK&gt;gcp *** Camera Settings ***  Manufacturer Name:Teledyne DALSA Model Name:      FA_81_8M100_01 Family Name:     Falcon2 Sensor Type:     Bayer Color Filter Array Device Version:  255.101.591 Manufacturer Info: Serial Number:   C123456 User Defined Name:myCamera Device Firmware  03-081-20261-06BETA FPGA Info:       Rev:46(8-4-2013 16:47) Calibration Date: 0 CPU Temp.:      39 [C] Sensor Temp.:   45 [C]  Default Set:     User Set 1 Frame Rate:     NA [Hz] Exposure Time:  NA [us] Exposure Mode:  TriggerWidth System Gain:    1.00 Red Gain:       1.00 Green Red Gain: 1.00 Blue Gain:      1.00 Green Blue Gain: 1.00 An. Coarse Gain: 2 Analog Offset:  0 Backgd Subtract: 0 Aspect Ratio:   4 to 3 Sensor Bit Depth: 8 [bpp] Test Image:     FPN Diagonal Ramp Test Static Value:0 CameraLink Taps: 10 [taps] Serial Baud Rate: 460800 AOI(x,y,w,h):   (0, 0, 3328, 2502) Trigger Mode:   External Trigger Source:  CC1 Trigger Delay:  0 [us]  ** General Purpose Input Settings ** Input Threshold: 2.4 [V] Name      Debounce      Inverter      State Line 1:   1                On            1 Line 2:   1                On            1 CC1:      1                On            0 CC2:      1                On            0 CC3:      1                On            0 CC4:      1                On            0  ** General Purpose Output Settings ** Name      Line Source Inverter  State  Delay(us)  Duration(us)  Sw.Latch Mode  Sw Line Val Line 3:   Off       On       1       0          1000          Off           Inactive Line 4:   Off       On       1       0          1000          Off           Inactive  ** Flatfield Settings ** FF Mode:      Calibration FF Set:       Userset 1 FF Cur Gain Mode: High Gain  Pix.Rep.Mode: Off Pix.Rep.Threshold:127 Pix.Rep.Algor.: Avg/Replace OK&gt; </pre>
<b>Full Name</b>	put camera in genicam mode
<b>Mnemonic</b>	gen
<b>Release</b>	6
<b>Notes</b>	The camera returns an OK> prompt then switches into GenICam mode.

<b>Full Name</b>	get values	
<b>Mnemonic</b>	get	
<b>Argument(s)</b>	command	String containing a command with a value associated with it(e.g. <i>ssf</i> , <i>ffm</i> , etc.)
<b>Release</b>	6	
<b>Notes</b>	The command does not return the units(e.g. <i>ssf</i> returns 30 without the Hz)	

<b>Full Name</b>	get line status	
<b>Mnemonic</b>	gls	
<b>Argument(s)</b>	line	L1: get status of general purpose input 1(line1) L2: get status of general purpose input 2(line2) CC1: get status of camera control line 1(CC1) CC2: get status of camera control line 2(CC2) CC3: get status of camera control line 3(CC3) CC4: get status of camera control line 4(CC4) L3: get status of general purpose output 1(line3) L4: get status of general purpose output 2(line4)
<b>GenICam</b>	<i>LineSelector</i> <i>LineStatus</i>	
<b>Release</b>	6	
<b>Notes</b>	Returns 1 for high and 0 for low	

<b>Full Name</b>	help	
<b>Mnemonic</b>	h	
<b>Release</b>	6	
<b>Notes</b>	Lists all of the camera's command. Commands that are not available due the camera's current settings have the text <i>Not Available</i> after the description.	

<b>Full Name</b>	single command help	
<b>Mnemonic</b>	?	
<b>Argument(s)</b>	command	A string containing the command for which help is requested.
<b>Notes</b>	This may supply more information than the <i>h</i> command e.g. <pre> OK&gt;? usd  usd  default user set          N F 1 2 3 4 Arg 1:       N:Nothing       F:Factory       1:User Set 1       2:User Set 2       3:User Set 3       4:User Set 4 </pre>	

<b>Full Name</b>	multiple aoi - mode	
<b>Mnemonic</b>	mam	
<b>Argument(s)</b>	mode	OFF:Single AOI ON: Multiple AOI
<b>GenICam</b>	<i>multipleAOIMode</i>	
<b>Release</b>	6	
<b>Notes</b>	Currently the only multiple AOI command.	

<b>Full Name</b>	pixel replacement algorithm	
<b>Mnemonic</b>	pra	
<b>Argument(s)</b>	algorithm	1:Average and Replace 2 adjacent pixels 3:Average and Weighted Average 2 adjacent pixels
<b>GenICam</b>	<i>flatfieldCorrectionPixelReplacementAlgorithm</i>	
<b>Release</b>	6	
<b>Notes</b>		

<b>Full Name</b>	pixel replacement mode	
<b>Mnemonic</b>	prm	
<b>Argument(s)</b>	mode	OFF:Don't replace ON: Replace
<b>GenICam</b>	<i>flatfieldCorrectionPixelReplacementMode</i>	
<b>Release</b>	6	
<b>Notes</b>	Controls enabling/disabling static pixel replacement	

<b>Full Name</b>	pixel replacement threshold	
<b>Mnemonic</b>	prt	
<b>Argument(s)</b>	threshold	1~127 : the fpn value above which pixels are marked as bad.
<b>GenICam</b>	<i>flatfieldCorrectionPixelReplacementThreshold</i>	
<b>Release</b>	6	
<b>Notes</b>	Changing this value will affect the flatfield statistics.	

<b>Full Name</b>	reset camera	
<b>Mnemonic</b>	rc	
<b>GenICam</b>	<i>DeviceReset</i>	
<b>Release</b>	6	
<b>Notes</b>	After sending this command, you will need to put the camera back into three letter command mode because the camera boots in GenICam mode at 9600 baud.	

<b>Full Name</b>	set analog course gain	
<b>Mnemonic</b>	sac	
<b>Argument(s)</b>	Gain	0,1,2,3 : gain index
<b>GenICam</b>	<i>GainSelector = AnalogAll</i> <i>Gain</i>	
<b>Release</b>	6	
<b>Notes</b>	Changing this value may require a recalibration of the camera's flat field values. See processing chain for more information	

<b>Full Name</b>	set analog offset	
<b>Mnemonic</b>	sao	
<b>Argument(s)</b>	offset	0~923: the dn to subtract from the cam
<b>GenICam</b>	<i>BlackLevelSelector = AnalogAll</i> <i>BlackLevel</i>	
<b>Release</b>	6	
<b>Notes</b>	Applies the offset correction to all analog taps See processing chain for more information	

<b>Full Name</b>	set aspect ratio	
<b>Mnemonic</b>	sar	
<b>Argument(s)</b>	ratio	2:Aspect 4to3 3:Aspect 1to1
<b>GenICam</b>	<i>sensorResolutionAspectRatio</i>	
<b>Release</b>	6	
<b>Notes</b>	Does not apply to 12M models. They have only a 4 to 3 aspect ratio. The camera stores separate AOIs for each aspect ratio.	

<b>Full Name</b>	set baud rate	
<b>Mnemonic</b>	sbr	
<b>Argument(s)</b>	Baud rate	9600 57600 115200 230400 460800
<b>GenICam</b>	<i>DeviceBaudRate</i>	
<b>Release</b>	6	
<b>Notes</b>	The camera will send an OK> prompt before switching the baud rate. Then the user will need to change the baud rate on the host application before proceeding.	

<b>Full Name</b>	set color gain	
<b>Mnemonic</b>	scg	
<b>Argument(s)</b>	color	R GR GB B
	gain	0.001~7.999
<b>GenICam</b>	<i>GainSelector = DigitalRed, DigitalBlue, DigitalGreenBlue, DigitalGreenRed</i> <i>Gain</i>	
<b>Release</b>	6	
<b>Notes</b>	Gain is express as a multiplication factor in increments of 1/1024. See processing chain for more information	

<b>Full Name</b>	set line detection level	
<b>Mnemonic</b>	sdl	
<b>Argument(s)</b>	threshold	0:2.4V 1:6.0V 2:12.0V
<b>GenICam</b>	<i>lineDetectionLevel</i>	
<b>Release</b>	6	
<b>Notes</b>	Only applies to general purpose input.	

<b>Full Name</b>	set exposure mode	
<b>Mnemonic</b>	sem	
<b>Argument(s)</b>	Mode	w:Trigger Width t:Timed
<b>GenICam</b>	<i>ExposureMode</i>	
<b>Release</b>	6	
<b>Notes</b>	Not available when stm = i. It will be forced to timed.	

<b>Full Name</b>	set exposure time	
<b>Mnemonic</b>	set	
<b>Argument(s)</b>	time	20 - 4000000 [us] external trigger 20 - (1/ FrameRate-overhead) [us] internal trigger
<b>GenICam</b>	<i>ExposureTime</i>	
<b>Release</b>	6	
<b>Notes</b>	Exposure time may be adjusted when changing the framerate.	

<b>Full Name</b>	set global FPN	
<b>Mnemonic</b>	sgf	
<b>Argument(s)</b>	offset	0~1023 [DN]
<b>GenICam</b>	<i>BlackLevelSelector=DigitalAll</i> <i>BlackLevel</i>	
<b>Release</b>	6	
<b>Notes</b>	See processing chain for more information	

<b>Full Name</b>	set input pixel size	
<b>Mnemonic</b>	sip	
<b>Argument(s)</b>	bits per pixel	8-10
<b>GenICam</b>	<i>pixelSizeInput</i>	
<b>Release</b>	6	
<b>Notes</b>	Color gain and factory ffc is dependant on this feature	

<b>Full Name</b>	set input debouncing	
<b>Mnemonic</b>	sid	
<b>Argument(s)</b>	inputLine	L1: general purpose input 1 L2: general purpose input 2 CC1: cameralink control line 1 CC2: cameralink control line 2 CC3: cameralink control line 3 CC4: cameralink control line 4
	debounceTime	0-255 [ $\mu$ s]
<b>GenICam</b>	<i>LineSelector</i> <i>lineDebouncingPeriod</i>	
<b>Release</b>	6	
<b>Notes</b>		

<b>Full Name</b>	set line inverter	
<b>Mnemonic</b>	sli	
<b>Argument(s)</b>	line	L1: general purpose input 1 L2: general purpose input 2 CC1: cameralink control line 1 CC2: cameralink control line 2 CC3: cameralink control line 3 CC4: cameralink control line 4 L3: general purpose output 1 L4: general purpose output 2
	mode	OFF ON
<b>GenICam</b>	<i>LineSelector</i> <i>LineInverter</i>	
<b>Release</b>	6	
<b>Notes</b>	See digital I/O for more information	

<b>Full Name</b>	set output pulse duration	
<b>Mnemonic</b>	sod	
<b>Argument(s)</b>	line	L3: general purpose output 1 L4: general purpose output 2
	duration	1~8388608 [ $\mu$ s]
<b>GenICam</b>	<i>LineSelector</i> <i>outputLinePulseDuration</i>	
<b>Release</b>	6	
<b>Notes</b>	Determines the length of the pulse output on the given line when the specified signal occurs.	



<b>Full Name</b>	set output line source	
<b>Mnemonic</b>	sos	
<b>Argument(s)</b>	line	L3: general purpose output 1 L4: general purpose output 2
	source	0:Start Internal ExSync 1:Start Exposure 2:End Exposure 3:Strt Readout 4:End Readout 5:End Internal EXSYNC 6:Start Line Active 7:GP Input 1 8:GP Input 2 9:CC1 10:CC2 11:CC3 12:CC4 13:End Line Active 30:Software Controlled 31:Off
<b>GenICam</b>	<i>LineSelector</i> <i>outputLineSource</i>	
<b>Release</b>	6	
<b>Notes</b>	Defines the internal signal to output on the specified general purpose output line.	

<b>Full Name</b>	set output pulse delay	
<b>Mnemonic</b>	soy	
<b>Argument(s)</b>	line	L3: general purpose output 1 L4: general purpose output 2
	delay	1~8388608 [ $\mu$ s]
<b>GenICam</b>	<i>LineSelector</i> <i>outputLinePulseDelay</i>	
<b>Release</b>	6	
<b>Notes</b>	The amount of time(in milliseconds) to delay the output pulse, after detecting a signal.	

<b>Full Name</b>	set pixel output format	
<b>Mnemonic</b>	spf	
<b>Argument(s)</b>	bitsPerPixel	8 10 (only available when using 8 camera link taps)
<b>GenICam</b>	<i>PixelFormat</i>	
<b>Release</b>	6	
<b>Notes</b>	Sets the pixel size of the camera output	

<b>Full Name</b>	set background subtract	
<b>Mnemonic</b>	ssb	
<b>Argument(s)</b>	offset	0 to 1023 [DN]
<b>GenICam</b>	<i>BlackLevelSelector = DigitalAll2</i> <i>BlackLevel</i>	
<b>Release</b>	6	
<b>Notes</b>	See processing chain for more information	

<b>Full Name</b>	set sync frequency	
<b>Mnemonic</b>	ssf	
<b>Argument(s)</b>	frequency	1 to max frame rate [Hz] Max Frame rate determined by AOI, pixel size, number of camera link taps etc.
<b>GenICam</b>	<i>AcquisitionFrameRate</i>	
<b>Release</b>	6	
<b>Notes</b>	Not available when the camera is externally triggered	

<b>Full Name</b>	set system gain	
<b>Mnemonic</b>	ssg	
<b>Argument(s)</b>	gain	0.001~7.999 in increments of 1/1024
<b>GenICam</b>	<i>GainSelector=DigitalAll</i> <i>Gain</i>	
<b>Release</b>	6	
<b>Notes</b>	Expressed as a multiplication factor See processing chain for more information.	

<b>Full Name</b>	set software latch	
<b>Mnemonic</b>	ssl	
<b>Argument(s)</b>	Line	L3: general purpose output 1 L4: general purpose output 2
	Mode	On: software latch is on Off: software latch is off
<b>GenICam</b>	<i>LineSelector</i> <i>outputLineSoftwareLatchControl</i>	
<b>Release</b>	6	
<b>Notes</b>	See digital I/O for more information	

<b>Full Name</b>	set trigger delay	
<b>Mnemonic</b>	std	
<b>Argument(s)</b>	Time	0~16777215 [us]
<b>GenICam</b>	<i>TriggerDelay</i>	
<b>Release</b>	6	
<b>Notes</b>		

<b>Full Name</b>	set trigger mode	
<b>Mnemonic</b>	stm	
<b>Argument(s)</b>	Mode	i:Internal e:External
<b>GenICam</b>	<i>TriggerMode</i>	
<b>Release</b>	6	
<b>Notes</b>		

<b>Full Name</b>	set trigger source	
<b>Mnemonic</b>	sts	
<b>Argument(s)</b>	Source	L1: general purpose input 1 L2: general purpose input 2 CC1: cameralink control line 1 CC2: cameralink control line 2 CC3: cameralink control line 3 CC4: cameralink control line 4 S: Software
<b>GenICam</b>	<i>TriggerSource</i>	
<b>Release</b>	6	
<b>Notes</b>		

<b>Full Name</b>	set video mode	
<b>Mnemonic</b>	Svm	
<b>Argument(s)</b>	mode	0:Video 1:Grey Horizontal Ramp 2:Grey Vertical Ramp 3:Purity 6:Grey Diagonal Ramp 7:FPN Diagonal Ramp 8:PRNU 13:Sensor Static Pattern 1 15:Sensor Dynamic Pattern 1 17:Static Value 18:FPN Coefficients
<b>GenICam</b>	<i>testImageSelector</i>	
<b>Release</b>	6	
<b>Notes</b>		

<b>Full Name</b>	Test pattern value	
<b>Mnemonic</b>	Tpv	
<b>Argument(s)</b>	Value	0~1023
<b>GenICam</b>	<i>testImageStaticValue</i>	
<b>Release</b>	6	
<b>Notes</b>	Applies to PRNU(svm 8) and StaticValue(svm 17)	

<b>Full Name</b>	verify temperature	
<b>Mnemonic</b>	Vt	
<b>Argument(s)</b>	Sensor	C:CPU Board S:Sensor Board
<b>GenICam</b>	<b>DeviceTemperatureSelector</b> <b>DeviceTemperature</b>	
<b>Release</b>	6	
<b>Notes</b>		

<b>Full Name</b>	default user set	
<b>Mnemonic</b>	usd	
<b>Argument(s)</b>	set name	N: Use default settings F: Factory Set 1: User Set 1 2: User Set 2 3: User Set 3 4: User Set 4
<b>GenICam</b>	<i>UserSetDefaultSelector</i>	
<b>Release</b>	6	
<b>Notes</b>	Specifies the set to load upon startup.	

<b>Full Name</b>	load user set	
<b>Mnemonic</b>	usl	
<b>Argument(s)</b>	set name	F: Factory Set 1: User Set 1 2: User Set 2 3: User Set 3 4: User Set 4
<b>GenICam</b>	<i>UserSetSelector</i> <i>UserSetLoad</i>	
<b>Release</b>	6	
<b>Notes</b>		

<b>Full Name</b>	Save user set	
<b>Mnemonic</b>	uss	
<b>Argument(s)</b>	set name	1: User Set 1 2: User Set 2 3: User Set 3 4: User Set 4
<b>GenICam</b>	<i>UserSetSelector</i> <i>UserSetSave</i>	
<b>Release</b>	6	
<b>Notes</b>		

---

# EMC Declaration of Conformity

We, **Teledyne DALSA**  
**605 McMurray Rd.,**  
**Waterloo, ON**  
**CANADA N2V 2E9**

declare under sole responsibility, that the product(s):

**FA-80-12M1H-XX-R**  
**FA-81-12M1H-XX-R**  
**FA-80-8M100-XX-R**  
**FA-81-8M100-XX-R**  
**FA-80-4M180-XX-R**  
**FA-81-4M180-XX-R**

fulfill(s) the requirements of the standard(s)

Radiated emissions requirements:

**EN 55022 (2006)**  
**EN 55011 (2009)**  
**ICES-003**  
**CISPR 22 (1993)**  
**CISPR 11**  
**FCC Part 15**

Immunity to disturbances:

**EN 55024 (1998)**  
**EN 61326-1 (2006)**

Place of Issue **Waterloo, ON, CANADA**  
Date of Issue **June 1, 2011**  
Name and Signature of **Hank Helmond**  
authorized person **Quality Manager, Teledyne DALSA Corp.**



# Revision History

Revision	Change Description	Date
00	Initial (Preliminary) release	11-Nov-11
01	Extensive revisions made throughout the manual in preparation for camera production and general release.	03-Feb-12
02	<ul style="list-style-type: none"> <li>-Additional commands added.</li> <li>-Color description and supporting technical content added.</li> <li>-Extensive revisions made throughout the Camera Operation section to add detail.</li> <li>-Power pinout illustration revised. Reversed pinout shown in rev 01.</li> <li>-Sensor block diagram and pixel readout diagram revised so that row 1 now shown in the correct configuration of green, blue, green, blue...</li> <li>-QE graph added.</li> <li>-EMC Compliance test results added.</li> </ul>	17-Apr-13
03	<p>Added three letter commands and added new features for version 6 of the microcode:</p> <ul style="list-style-type: none"> <li>-Gain Selector command: AnalogAllRaw 1 and AnalogAllRaw 2 values added .</li> <li>-sensorFirstFrameClearMode command added .</li> <li>-sensorPRPtime command added .</li> <li>-flatfieldCorrectionPixelReplacementAlgorithm(s) revised .</li> <li>-flatfieldCalibrationPixelReplacementGainThreshold revised .</li> <li>-flatfieldCalibrationUncorrectableHotPixels command added .</li> <li>-flatfieldCalibrationDeadPixelsReplaced command added .</li> <li>-flatfieldCalibrationUncorrectableDeadPixels command added .</li> <li>-flatfieldCalibrationDeadPixelsReplaced command removed .</li> <li>-flatfieldCalculatePixelStatistics command added .</li> <li>-Description of test patterns revised .</li> </ul>	02-Aug-13

# Index

## A

antiblooming, 8

## B

block diagram  
sensor, 15

## C

Camera Link  
cables, 93  
input signals, 20  
outputs, 20, 93  
Camera Link connector, 93  
certifications, 9  
cleaning  
sensor window, 100  
clock signals, 93  
compliance, 9  
connectors, 18  
Camera Link, 93  
location, 18  
power, 19  
cosmetic specifications, 14

## D

data bus, 20, 93  
DC offset, 8

## E

EMC Declaration of  
Conformity, 118  
exposure  
control, 37  
external frame rate,  
programmable exposure time,  
39  
externally controlled, 38  
internally controlled, 37  
exposure modes  
descriptions of, 37  
exposure time  
set, 39

## F

factory settings, 26

frame rate  
set, 40  
frame rates, 9

## G

grounding instructions, 18  
GUI  
overview, 21

## I

I/O  
control, 41  
image acquisition, 37  
Input / Output  
control, 41  
input/ output, 18  
interface  
mechanical, 8

## L

LED  
definitions, 20  
line rate, 40

## M

mechanical  
camera, 16  
specifications, 8  
models, 7

## O

operating  
ranges, 8, 9  
optocouplers, 49

## P

performance specifications, 8  
pixel readout, 15  
power  
connector, 19  
connectors, 19  
guidelines, 19  
precautions, 5

**Q**

quantum efficiency  
graph, 13

**R**

random noise, 8  
requirements  
  PC, 17  
responsivity, 8  
  graph, 11  
revision history, 119

**S**

safety, 5

settings  
  factory, 26  
setup  
  overview, 17  
software  
  required, 7  
specifications  
  mechanical, 8  
  operating, 8, 9  
  performance, 8

**T**

trigger modes, 48